

Corus Construction & Industrial

Structural sections

CE marked structural sections

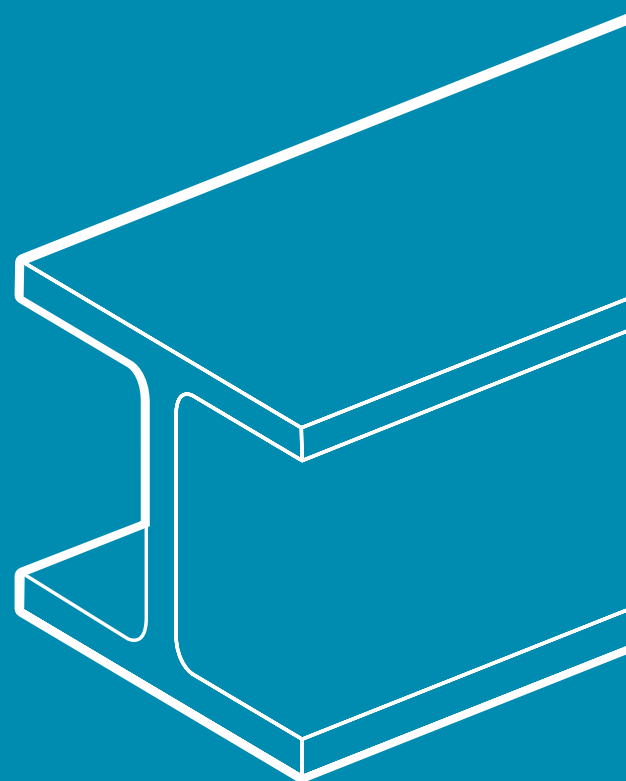

Contents

Dimensions and properties	
Universal Beams	Page 4
Universal Columns	Page 8
Universal Bearing Piles	Page 10
Parallel Flange Channels	Page 10
Asymmetric Slimflor® Beams (ASB)	Page 12
Angles	
Equal	Page 14
Unequal	Page 16
Product specifications/tolerances	Page 18
Offices and agents for Corus products	Page 24
Technical support for the construction industry	Page 26

Universal Beams

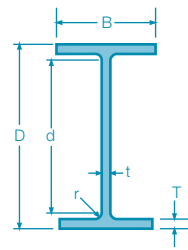

Designation		Mass per metre kg/m	Depth of section D mm	Width of section B mm	Thickness of web t mm	Thickness of flange T mm	Root radius r mm	Depth between fillets d mm	Ratios for local buckling		Second moment of area		Radius of gyration		
Serial size									Flange B/2T	Web d/t	Axis x-x cm ⁴	Axis y-y cm ⁴	Axis x-x cm	Axis y-y cm	
➤	1016x305	487	486.7	1036.3	308.5	30.0	54.1	30.0	868.1	2.85	28.9	1021884	26721	40.6	6.57
➤	437	437.0	1026.1	305.4	26.9	49.0	30.0	868.1	3.12	32.3	910322	23447	40.4	6.49	
➤	393	392.7	1015.9	303.0	24.4	43.9	30.0	868.1	3.45	35.6	807503	20496	40.2	6.40	
➤	349	349.4	1008.1	302.0	21.1	40.0	30.0	868.1	3.78	41.1	723131	18460	40.3	6.44	
➤	314	314.3	999.9	300.0	19.1	35.9	30.0	868.1	4.18	45.5	644063	16232	40.1	6.37	
➤	272	272.3	990.1	300.0	16.5	31.0	30.0	868.1	4.84	52.6	553974	14004	40.0	6.35	
➤	249	248.7	980.1	300.0	16.5	26.0	30.0	868.1	5.77	52.6	481192	11754	39.0	6.09	
➤	222	222.0	970.3	300.0	16.0	21.1	30.0	868.1	7.11	54.3	407961	9546	38.0	5.81	
	914x419	388	388.0	921.0	420.5	21.4	36.6	24.1	799.6	5.74	37.4	719635	45438	38.2	9.59
	343	343.3	911.8	418.5	19.4	32.0	24.1	799.6	6.54	41.2	625780	39156	37.8	9.46	
	914x305	289	289.1	926.6	307.7	19.5	32.0	19.1	824.4	4.81	42.3	504187	15597	37.0	6.51
	253	253.4	918.4	305.5	17.3	27.9	19.1	824.4	5.47	47.7	436305	13301	36.8	6.42	
	224	224.2	910.4	304.1	15.9	23.9	19.1	824.4	6.36	51.8	376414	11236	36.3	6.27	
	201	200.9	903.0	303.3	15.1	20.2	19.1	824.4	7.51	54.6	325254	9423	35.7	6.07	
	838x292	226	226.5	850.9	293.8	16.1	26.8	17.8	761.7	5.48	47.3	339704	11360	34.3	6.27
	194	193.8	840.7	292.4	14.7	21.7	17.8	761.7	6.74	51.8	279175	9066	33.6	6.06	
	176	175.9	834.9	291.7	14.0	18.8	17.8	761.7	7.76	54.4	246021	7799	33.1	5.90	
	762x267	197	196.8	769.8	268.0	15.6	25.4	16.5	686.0	5.28	44.0	239957	8175	30.9	5.71
	173	173.0	762.2	266.7	14.3	21.6	16.5	686.0	6.17	48.0	205282	6850	30.5	5.58	
	147	146.9	754.0	265.2	12.8	17.5	16.5	686.0	7.58	53.6	168502	5455	30.0	5.40	
	134	133.9	750.0	264.4	12.0	15.5	16.5	686.0	8.53	57.2	150692	4788	29.7	5.30	
	686x254	170	170.2	692.9	255.8	14.5	23.7	15.2	615.1	5.40	42.4	170326	6630	28.0	5.53
	152	152.4	687.5	254.5	13.2	21.0	15.2	615.1	6.06	46.6	150355	5784	27.8	5.46	
	140	140.1	683.5	253.7	12.4	19.0	15.2	615.1	6.68	49.6	136267	5183	27.6	5.39	
	125	125.2	677.9	253.0	11.7	16.2	15.2	615.1	7.81	52.6	117992	4383	27.2	5.24	
	610x305	238	238.1	635.8	311.4	18.4	31.4	16.5	540.0	4.96	29.3	209471	15837	26.3	7.23
	179	179.0	620.2	307.1	14.1	23.6	16.5	540.0	6.51	38.3	153024	11408	25.9	7.07	
	149	149.2	612.4	304.8	11.8	19.7	16.5	540.0	7.74	45.8	125876	9308	25.7	7.00	
	610x229	140	139.9	617.2	230.2	13.1	22.1	12.7	547.6	5.21	41.8	111777	4505	25.0	5.03
	125	125.1	612.2	229.0	11.9	19.6	12.7	547.6	5.84	46.0	98610	3932	24.9	4.97	
	113	113.0	607.6	228.2	11.1	17.3	12.7	547.6	6.60	49.3	87318	3434	24.6	4.88	
	101	101.2	602.6	227.6	10.5	14.8	12.7	547.6	7.69	52.2	75780	2915	24.2	4.75	
➤	610x178	100	100.3	607.4	179.2	11.3	17.2	12.7	547.6	5.21	48.5	72528	1658	23.8	3.60
➤	92	92.2	603.0	178.8	10.9	15.0	12.7	547.6	5.96	50.2	64577	1436	23.4	3.50	
➤	82	81.8	598.6	177.9	10.0	12.8	12.7	547.6	6.95	54.8	55869	1207	23.2	3.40	
➤	533x312	272	273.3	577.1	320.2	21.1	37.6	12.7	476.5	4.26	22.6	198578	20615	23.9	7.70
➤	219	218.8	560.3	317.4	18.3	29.2	12.7	476.5	5.43	26.0	150976	15589	23.3	7.48	
➤	182	181.5	550.7	314.5	15.2	24.4	12.7	476.5	6.44	31.3	123222	12667	23.1	7.40	
➤	150	150.6	542.5	312.0	12.7	20.3	12.7	476.5	7.68	37.5	100633	10285	22.9	7.32	
➤	533x210	138	138.3	549.1	213.9	14.7	23.6	12.7	476.5	4.53	32.4	86088	3864	22.1	4.68
	122	122.0	544.5	211.9	12.7	21.3	12.7	476.5	4.97	37.5	76043	3388	22.1	4.67	
	109	109.0	539.5	210.8	11.6	18.8	12.7	476.5	5.61	41.1	66822	2943	21.9	4.60	
	101	101.0	536.7	210.0	10.8	17.4	12.7	476.5	6.03	44.1	61519	2692	21.9	4.57	
	92	92.1	533.1	209.3	10.1	15.6	12.7	476.5	6.71	47.2	55227	2389	21.7	4.51	
	82	82.2	528.3	208.8	9.6	13.2	12.7	476.5	7.91	49.6	47539	2007	21.3	4.38	
➤	533x165	85	84.8	534.9	166.5	10.3	16.5	12.7	476.5	5.05	46.3	48631	1275	21.2	3.44
➤	74	74.7	529.1	165.9	9.7	13.6	12.7	476.5	6.10	49.1	41058	1040	20.8	3.30	
➤	66	65.7	524.7	165.1	8.9	11.4	12.7	476.5	7.24	53.5	35028	859	20.5	3.20	

Dimensions and properties to BS4-1:2005.

➤ These dimensions are in addition to our standard range of BS4 sections.

* Sections in italics may become slender under axial compression.

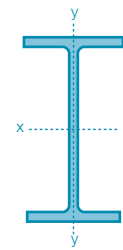

Elastic modulus		Plastic modulus		Buckling parameter	Torsional index	Warping constant	Torsional constant	Area of section	Indicative values for S275 steel for $L_c=3.5m$		Designation	
Axis x-x	Axis y-y	Axis x-x	Axis y-y	u	x	H	J	cm ²	Mcx	Pcy*	Serial size	
cm ³	cm ³	cm ³	cm ³			dm ⁶	cm ⁴		kNm	kN		
19722	1732	23208	2799	0.867	21.1	64.4	4299	620	5920	12400	487	1016x305
17743	1535	20769	2467	0.868	23.1	56.0	3185	557	5300	11600	437	
15897	1353	18538	2167	0.868	25.5	48.4	2330	500	4730	10300	393	
14346	1223	16593	1940	0.872	27.9	43.3	1718	445	4400	9900	349	
12883	1082	14850	1712	0.872	30.7	37.7	1264	400	3940	8860	314	
11190	934	12827	1469	0.873	35.0	32.2	835	347	3400	7090	272	
9819	784	11350	1244	0.861	39.8	26.8	582	317	3010	6330	249	
8409	636	9808	1019	0.850	45.7	21.5	390	283	2600	5450	222	
15627	2161	17666	3340	0.885	26.7	88.9	1734	494	4680	12100	388	914x419
13726	1871	15478	2889	0.883	30.1	75.8	1193	437	4100	10700	343	
10883	1014	12570	1601	0.867	31.9	31.2	926	368	3330	8220	289	914x305
9501	871	10942	1370	0.866	36.2	26.4	626	323	2900	6800	253	
8269	739	9535	1163	0.861	41.3	22.1	422	286	2530	5790	224	
7204	621	8352	982	0.854	46.8	18.4	291	256	2210	5000	201	
7985	773	9155	1211	0.870	35.0	19.3	514	289	2430	6060	226	838x292
6641	620	7640	974	0.862	41.6	15.2	306	247	2020	4950	194	
5893	535	6808	842	0.856	46.5	13.0	221	224	1800	4350	176	
6234	610	7167	958	0.869	33.2	11.3	404	251	1900	5310	197	762x267
5387	514	6198	807	0.864	38.1	9.39	267	220	1640	4510	173	
4470	411	5156	647	0.858	45.2	7.40	159	187	1370	3520	147	
4018	362	4644	570	0.854	49.8	6.46	119	171	1280	3200	134	
4916	518	5631	811	0.872	31.8	7.42	308	217	1490	4520	170	686x254
4374	455	5001	710	0.871	35.5	6.42	220	194	1330	4010	152	
3987	409	4558	638	0.868	38.7	5.72	169	178	1210	3450	140	
3481	346	3994	542	0.862	43.9	4.80	116	159	1060	2970	125	
6589	1017	7486	1574	0.886	21.3	14.5	785	303	1980	7000	238	610x305
4935	743	5548	1144	0.886	27.7	10.2	340	228	1470	5230	179	
4111	611	4594	937	0.886	32.7	8.17	200	190	1220	4210	149	
3622	391	4142	611	0.875	30.6	3.99	216	178	1100	3510	140	610x229
3221	343	3676	535	0.873	34.1	3.45	154	159	974	3110	125	
2874	301	3281	469	0.870	38.0	2.99	111	144	869	2780	113	
2515	256	2881	400	0.864	43.1	2.52	77.0	129	792	2340	101	
2388	185	2786	296	0.855	38.7	1.44	95.0	128	738	1840	100	610x178
2142	161	2511	258	0.848	42.8	1.24	71.0	117	691	1650	92	
1867	136	2194	218	0.843	48.5	1.04	48.8	104	603	1410	82	
6882	1288	7859	1985	0.890	15.9	15.0	1288	348	2083	8170	272	533x312
5389	982	6109	1514	0.884	19.8	11.0	642	279	1619	6500	219	
4475	806	5030	1237	0.885	23.4	8.77	373	231	1333	5370	182	
3710	659	4142	1009	0.885	27.8	7.01	216	192	1098	4450	150	
3136	361	3613	568	0.873	25.0	2.67	250	176	957	3290	138	533x210
2793	320	3196	500	0.877	27.6	2.32	178	155	847	2900	122	
2477	279	2829	436	0.875	30.9	1.99	126	139	750	2570	109	
2292	256	2612	399	0.874	33.2	1.81	101	129	692	2370	101	
2072	228	2360	355	0.872	36.5	1.60	75.7	117	649	2180	92	
1800	192	2059	300	0.864	41.6	1.33	51.5	105	566	1910	82	
1818	153	2107	243	0.862	35.5	0.857	73.8	108	558	1460	85	533x165
1552	125	1808	200	0.853	41.1	0.691	47.9	95.2	497	1240	74	
1335	104	1561	166	0.847	47.0	0.566	32.0	83.7	429	1040	66	

Universal Beams

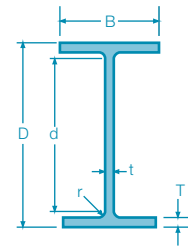

Designation		Mass per metre kg/m	Depth of section D mm	Width of section B mm	Thickness of web t mm	Thickness of flange T mm	Root radius r mm	Depth between fillets d mm	Ratios for local buckling		Second moment of area		Radius of gyration		
Serial size									Flange B/2T	Web d/t	Axis x-x cm ⁴	Axis y-y cm ⁴	Axis x-x cm	Axis y-y cm	
➤	457x191	161	161.4	492.0	199.4	18.0	32.0	10.2	407.6	3.12	22.6	79779	4250	19.7	4.55
		133	133.3	480.6	196.7	15.3	26.3	10.2	407.6	3.74	26.6	63841	3350	19.4	4.44
		106	105.8	469.2	194.0	12.6	20.6	10.2	407.6	4.71	32.3	48873	2515	19.0	4.32
		98	98.3	467.2	192.8	11.4	19.6	10.2	407.6	4.92	35.8	45727	2347	19.1	4.33
		89	89.3	463.4	191.9	10.5	17.7	10.2	407.6	5.42	38.8	41015	2089	19.0	4.29
		82	82.0	460.0	191.3	9.9	16.0	10.2	407.6	5.98	41.2	37051	1871	18.8	4.23
		74	74.3	457.0	190.4	9.0	14.5	10.2	407.6	6.57	45.3	33319	1671	18.8	4.20
	67	67.1	453.4	189.9	8.5	12.7	10.2	407.6	7.48	48.0	29380	1452	18.5	4.12	
➤	457x152	82	82.1	465.8	155.3	10.5	18.9	10.2	407.6	4.11	38.8	36589	1185	18.7	3.37
		74	74.2	462.0	154.4	9.6	17.0	10.2	407.6	4.54	42.5	32674	1047	18.6	3.33
		67	67.2	458.0	153.8	9.0	15.0	10.2	407.6	5.13	45.3	28927	913	18.4	3.27
		60	59.8	454.6	152.9	8.1	13.3	10.2	407.6	5.75	50.3	25500	795	18.3	3.23
		52	52.3	449.8	152.4	7.6	10.9	10.2	407.6	6.99	53.6	21369	645	17.9	3.11
➤	406x178	85	85.3	417.2	181.9	10.9	18.2	10.2	360.4	5.00	33.1	31703	1830	17.1	4.11
		74	74.2	412.8	179.5	9.5	16.0	10.2	360.4	5.61	37.9	27310	1545	17.0	4.04
		67	67.1	409.4	178.8	8.8	14.3	10.2	360.4	6.25	41.0	24331	1365	16.9	3.99
		60	60.1	406.4	177.9	7.9	12.8	10.2	360.4	6.95	45.6	21596	1203	16.8	3.97
		54	54.1	402.6	177.7	7.7	10.9	10.2	360.4	8.15	46.8	18722	1021	16.5	3.85
➤	406x140	53	53.3	406.6	143.3	7.9	12.9	10.2	360.4	5.55	45.6	18283	635	16.4	3.06
		46	46.0	403.2	142.2	6.8	11.2	10.2	360.4	6.35	53.0	15685	538	16.4	3.03
		39	39.0	398.0	141.8	6.4	8.6	10.2	360.4	8.24	56.3	12508	410	15.9	2.87
➤	356x171	67	67.1	363.4	173.2	9.1	15.7	10.2	311.6	5.52	34.2	19463	1362	15.1	3.99
		57	57.0	358.0	172.2	8.1	13.0	10.2	311.6	6.62	38.5	16038	1108	14.9	3.91
		51	51.0	355.0	171.5	7.4	11.5	10.2	311.6	7.46	42.1	14136	968	14.8	3.86
		45	45.0	351.4	171.1	7.0	9.7	10.2	311.6	8.82	44.5	12066	811	14.5	3.76
➤	356x127	39	39.1	353.4	126.0	6.6	10.7	10.2	311.6	5.89	47.2	10172	358	14.3	2.68
		33	33.1	349.0	125.4	6.0	8.5	10.2	311.6	7.38	51.9	8249	280	14.0	2.58
➤	305x165	54	54.0	310.4	166.9	7.9	13.7	8.9	265.2	6.09	33.6	11696	1063	13.0	3.93
		46	46.1	306.6	165.7	6.7	11.8	8.9	265.2	7.02	39.6	9899	896	13.0	3.90
		40	40.3	303.4	165.0	6.0	10.2	8.9	265.2	8.09	44.2	8503	764	12.9	3.86
➤	305x127	48	48.1	311.0	125.3	9.0	14.0	8.9	265.2	4.48	29.5	9575	461	12.5	2.74
		42	41.9	307.2	124.3	8.0	12.1	8.9	265.2	5.14	33.2	8196	389	12.4	2.70
		37	37.0	304.4	123.4	7.1	10.7	8.9	265.2	5.77	37.4	7171	336	12.3	2.67
➤	305x102	33	32.8	312.7	102.4	6.6	10.8	7.6	275.9	4.74	41.8	6501	194	12.5	2.15
		28	28.2	308.7	101.8	6.0	8.8	7.6	275.9	5.78	46.0	5366	155	12.2	2.08
		25	24.8	305.1	101.6	5.8	7.0	7.6	275.9	7.26	47.6	4455	123	11.9	1.97
➤	254x146	43	43.0	259.6	147.3	7.2	12.7	7.6	219.0	5.80	30.4	6544	677	10.9	3.52
		37	37.0	256.0	146.4	6.3	10.9	7.6	219.0	6.72	34.8	5537	571	10.8	3.48
		31	31.1	251.4	146.1	6.0	8.6	7.6	219.0	8.49	36.5	4413	448	10.5	3.36
➤	254x102	28	28.3	260.4	102.2	6.3	10.0	7.6	225.2	5.11	35.7	4005	179	10.5	2.22
		25	25.2	257.2	101.9	6.0	8.4	7.6	225.2	6.07	37.5	3415	149	10.3	2.15
		22	22.0	254.0	101.6	5.7	6.8	7.6	225.2	7.47	39.5	2841	119	10.1	2.06
➤	203x133	30	30.0	206.8	133.9	6.4	9.6	7.6	172.4	6.97	26.9	2896	385	8.71	3.17
		25	25.1	203.2	133.2	5.7	7.8	7.6	172.4	8.54	30.2	2340	308	8.56	3.10
➤	203x102	23	23.1	203.2	101.8	5.4	9.3	7.6	169.4	5.47	31.4	2105	164	8.46	2.36
➤	178x102	19	19.0	177.8	101.2	4.8	7.9	7.6	146.8	6.41	30.6	1356	137	7.48	2.37
➤	152x89	16	16.0	152.4	88.7	4.5	7.7	7.6	121.8	5.76	27.1	834	90	6.41	2.10
➤	127x76	13	13.0	127.0	76.0	4.0	7.6	7.6	96.6	5.00	24.2	473	56	5.35	1.84

Dimensions and properties to BS4-1:2005.

➤ These dimensions are in addition to our standard range of BS4 sections.

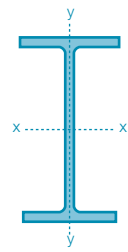

Elastic modulus		Plastic modulus		Buckling parameter	Torsional index	Warping constant	Torsional constant	Area of section	Indicative values for S275 steel for $L_c=3.5m$		Designation	
Axis x-x	Axis y-y	Axis x-x	Axis y-y	u	x	H	J	cm ²	M _{cx}	P _{cy}	Serial size	
cm ³	cm ³	cm ³	cm ³			dm ⁶	cm ⁴		kNm	kN		
3243	426	3778	672	0.882	16.4	2.25	515	206	1000	3770	161	457x191
2657	341	3070	535	0.880	19.6	1.73	292	170	814	3050	133	
2083	259	2389	405	0.877	24.4	1.27	146	135	633	2360	106	
1957	243	2232	379	0.881	25.7	1.18	121	125	592	2190	98	
1770	218	2014	338	0.880	28.3	1.04	90.7	114	534	1980	89	
1611	196	1831	304	0.877	30.9	0.922	69.2	104	504	1830	82	
1458	176	1653	272	0.877	33.9	0.818	51.8	94.6	455	1650	74	
1296	153	1471	237	0.872	37.9	0.705	37.1	85.5	405	1460	67	
1571	153	1812	240	0.873	27.4	0.591	89.2	105	480	1380	82	457x152
1414	136	1627	213	0.873	30.1	0.518	65.9	94.5	431	1220	74	
1263	119	1453	187	0.869	33.6	0.448	47.7	85.6	400	1100	67	
1122	104	1287	163	0.868	37.5	0.387	33.8	76.2	354	959	60	
950	85	1096	133	0.859	43.9	0.311	21.4	66.6	301	793	52	
1520	201	1733	313	0.881	24.4	0.728	93.0	109	459	1820	85	406x178
1323	172	1501	267	0.882	27.6	0.608	62.8	94.5	413	1580	74	
1189	153	1346	237	0.880	30.5	0.533	46.1	85.5	370	1410	67	
1063	135	1200	209	0.880	33.8	0.466	33.3	76.5	330	1260	60	
930	115	1055	178	0.871	38.3	0.392	23.1	69.0	290	1090	54	
899	89	1031	139	0.870	34.1	0.246	29.0	67.9	284	789	53	406x140
778	76	888	118	0.871	38.9	0.207	19.0	58.6	244	671	46	
629	58	724	91	0.858	47.5	0.155	10.7	49.7	199	523	39	
1071	157	1211	243	0.886	24.4	0.412	55.7	85.5	333	1410	67	356x171
896	129	1010	199	0.882	28.8	0.330	33.4	72.6	278	1170	57	
796	113	896	174	0.881	32.1	0.286	23.8	64.9	246	1030	51	
687	95	775	147	0.874	36.8	0.237	15.8	57.3	213	884	45	
576	57	659	89	0.871	35.2	0.105	15.1	49.8	181	469	39	356x127
473	45	543	70	0.863	42.2	0.0812	8.79	42.1	149	372	33	
754	127	846	196	0.889	23.6	0.234	34.8	68.8	233	1120	54	305x165
646	108	720	166	0.891	27.1	0.195	22.2	58.7	198	945	46	
560	93	623	142	0.889	31.0	0.164	14.7	51.3	171	816	40	
616	74	711	116	0.873	23.3	0.102	31.8	61.2	195	597	48	305x127
534	63	614	98	0.872	26.5	0.0846	21.1	53.4	169	509	42	
471	54	539	85	0.872	29.7	0.0725	14.8	47.2	148	442	37	
416	38	481	60	0.866	31.6	0.0442	12.2	41.8	132	269	33	305x102
348	31	403	48	0.859	37.4	0.0349	7.40	35.9	111	218	28	
292	24	342	39	0.846	43.4	0.0273	4.77	31.6	94.1	174	25	
504	92	566	141	0.891	21.2	0.103	23.9	54.8	156	777	43	254x146
433	78	483	119	0.890	24.3	0.0857	15.3	47.2	133	659	37	
351	61	393	94	0.880	29.6	0.0660	8.55	39.7	108	529	31	
308	35	353	55	0.874	27.5	0.0280	9.57	36.1	97.0	246	28	254x102
266	29	306	46	0.866	31.5	0.0230	6.42	32.0	84.0	206	25	
224	23	259	37	0.856	36.4	0.0182	4.15	28.0	71.2	167	22	
280	57	314	88	0.881	21.5	0.0374	10.3	38.2	86.5	468	30	203x133
230	46	258	71	0.877	25.6	0.0294	5.96	32.0	70.9	379	25	
207	32	234	50	0.888	22.5	0.0154	7.02	29.4	64.4	223	23	203x102
153	27	171	42	0.888	22.6	0.0099	4.41	24.3	47.1	186	19	178x102
109	20	123	31	0.890	19.6	0.0047	3.56	20.3	33.9	125	16	152x89
75	15	84	23	0.895	16.3	0.0020	2.85	16.5	23.1	80.3	13	127x76

Universal Columns

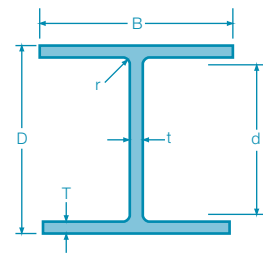

Designation		Mass per metre kg/m	Depth of section D mm	Width of section B mm	Thickness of web t mm	Thickness of flange T mm	Root radius r mm	Depth between fillets d mm	Ratios for local buckling		Second moment of area		Radius of gyration	
Serial size									Flange B/2T	Web d/t	Axis x-x cm ⁴	Axis y-y cm ⁴	Axis x-x cm	Axis y-y cm
356x406	634	633.9	474.6	424.0	47.6	77.0	15.2	290.2	2.75	6.10	274845	98125	18.4	11.0
	551	551.0	455.6	418.5	42.1	67.5	15.2	290.2	3.10	6.89	226938	82671	18.0	10.9
	467	467.0	436.6	412.2	35.8	58.0	15.2	290.2	3.55	8.11	183003	67834	17.5	10.7
	393	393.0	419.0	407.0	30.6	49.2	15.2	290.2	4.14	9.48	146618	55367	17.1	10.5
	340	339.9	406.4	403.0	26.6	42.9	15.2	290.2	4.70	10.9	122543	46853	16.8	10.4
	287	287.1	393.6	399.0	22.6	36.5	15.2	290.2	5.47	12.8	99875	38677	16.5	10.3
	235	235.1	381.0	394.8	18.4	30.2	15.2	290.2	6.54	15.8	79085	30993	16.3	10.2
356x368	202	201.9	374.6	374.7	16.5	27.0	15.2	290.2	6.94	17.6	66261	23688	16.1	9.60
	177	177.0	368.2	372.6	14.4	23.8	15.2	290.2	7.83	20.2	57118	20529	15.9	9.54
	153	152.9	362.0	370.5	12.3	20.7	15.2	290.2	8.95	23.6	48589	17553	15.8	9.49
	129	129.0	355.6	368.6	10.4	17.5	15.2	290.2	10.5	27.9	40246	14611	15.6	9.43
305x305	283	282.9	365.3	322.2	26.8	44.1	15.2	246.7	3.65	9.21	78872	24635	14.8	8.27
	240	240.0	352.5	318.4	23.0	37.7	15.2	246.7	4.22	10.7	64203	20315	14.5	8.15
	198	198.1	339.9	314.5	19.1	31.4	15.2	246.7	5.01	12.9	50904	16299	14.2	8.04
	158	158.1	327.1	311.2	15.8	25.0	15.2	246.7	6.22	15.6	38747	12569	13.9	7.90
	137	136.9	320.5	309.2	13.8	21.7	15.2	246.7	7.12	17.9	32814	10700	13.7	7.83
	118	117.9	314.5	307.4	12.0	18.7	15.2	246.7	8.22	20.6	27672	9059	13.6	7.77
	97	96.9	307.9	305.3	9.9	15.4	15.2	246.7	9.91	24.9	22249	7308	13.4	7.69
254x254	167	167.1	289.1	265.2	19.2	31.7	12.7	200.3	4.18	10.4	29998	9870	11.9	6.81
	132	132.0	276.3	261.3	15.3	25.3	12.7	200.3	5.16	13.1	22529	7531	11.6	6.69
	107	107.1	266.7	258.8	12.8	20.5	12.7	200.3	6.31	15.6	17510	5928	11.3	6.59
	89	88.9	260.3	256.3	10.3	17.3	12.7	200.3	7.41	19.4	14268	4857	11.2	6.55
	73	73.1	254.1	254.6	8.6	14.2	12.7	200.3	8.96	23.3	11407	3908	11.1	6.48
➤ 203x203	127	127.5	241.4	213.9	18.1	30.1	10.2	160.8	3.55	8.88	15437	4920	9.75	5.50
	113	113.5	235.0	212.1	16.3	26.9	10.2	160.8	3.94	9.87	13301	4285	9.59	5.45
	100	99.6	228.6	210.3	14.5	23.7	10.2	160.8	4.44	11.1	11298	3679	9.44	5.39
	86	86.1	222.2	209.1	12.7	20.5	10.2	160.8	5.10	12.7	9449	3127	9.28	5.34
	71	71.0	215.8	206.4	10.0	17.3	10.2	160.8	5.97	16.1	7618	2537	9.18	5.30
	60	60.0	209.6	205.8	9.4	14.2	10.2	160.8	7.25	17.1	6125	2065	8.96	5.20
	52	52.0	206.2	204.3	7.9	12.5	10.2	160.8	8.17	20.4	5259	1778	8.91	5.18
46	46.1	203.2	203.6	7.2	11.0	10.2	160.8	9.25	22.3	4568	1548	8.82	5.13	
➤ 152x152	51	51.2	170.2	157.4	11.0	15.7	7.6	123.6	5.01	11.2	3227	1022	7.04	3.96
	44	44.0	166.0	155.9	9.5	13.6	7.6	123.6	5.73	13.0	2703	860	6.94	3.92
	37	37.0	161.8	154.4	8.0	11.5	7.6	123.6	6.71	15.5	2210	706	6.85	3.87
	30	30.0	157.6	152.9	6.5	9.4	7.6	123.6	8.13	19.0	1748	560	6.76	3.83
	23	23.0	152.4	152.2	5.8	6.8	7.6	123.6	11.2	21.3	1250	400	6.54	3.70

Dimensions and properties to BS4-1:2005.

➤ These dimensions are in addition to our standard range of BS4 sections.

⌘ Capacities in italics are governed by 1.2 x Z_x, x p_y.

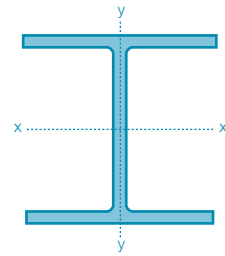

Elastic modulus		Plastic modulus		Buckling parameter	Torsional index	Warping constant	Torsional constant	Area of section	Indicative values for S275 steel		Designation	
Axis x-x	Axis y-y	Axis x-x	Axis y-y	u	x	H	J	cm ²	Mc _x ^s	P _{cy} for L _c =3.5m	Serial size	
cm ³	cm ³	cm ³	cm ³			dm ⁶	cm ⁴		kNm	kN		
11582	4629	14235	7108	0.843	5.46	38.8	13720	808	3410	17600	634	356x406
9962	3951	12076	6058	0.841	6.05	31.1	9240	702	2930	15300	551	
8383	3291	10003	5034	0.839	6.86	24.3	5809	595	2550	13400	467	
6998	2721	8223	4154	0.837	7.86	18.9	3545	501	2100	11400	393	
6031	2325	6999	3544	0.836	8.85	15.5	2343	433	1780	9840	340	
5075	1939	5813	2949	0.835	10.2	12.3	1441	366	1540	8780	287	
4151	1570	4687	2383	0.834	12.1	9.54	812	299	1240	7150	235	
3538	1264	3972	1919	0.844	13.4	7.16	558	257	1050	6060	202	356x368
3103	1102	3455	1671	0.844	15.0	6.09	381	226	916	5320	177	
2684	948	2965	1435	0.844	17.0	5.11	251	195	786	4590	153	
2264	793	2479	1199	0.844	19.9	4.18	153	164	651	3850	129	
4318	1529	5105	2342	0.855	7.65	6.35	2034	360	1300	7640	283	305x305
3643	1276	4247	1950	0.854	8.74	5.03	1271	306	1130	6890	240	
2995	1037	3440	1581	0.854	10.2	3.88	734	252	912	5650	198	
2369	808	2681	1230	0.851	12.5	2.87	378	201	710	4480	158	
2048	692	2297	1052	0.851	14.2	2.39	249	174	609	3870	137	
1760	589	1958	895	0.850	16.2	1.98	161	150	519	3330	118	
1445	479	1592	726	0.850	19.3	1.56	91.2	123	438	2810	97	
2075	744	2424	1137	0.851	8.49	1.63	626	213	642	4490	167	254x254
1631	576	1869	878	0.850	10.3	1.19	319	168	495	3510	132	
1313	458	1485	697	0.848	12.4	0.898	172	136	393	2820	107	
1096	379	1224	575	0.850	14.5	0.717	102	113	324	2340	89	
898	307	992	465	0.849	17.3	0.562	57.6	93.1	273	1980	73	
1279	460	1517	704	0.854	7.38	0.549	427	162	402	3050	127	203x203
1132	404	1329	618	0.853	8.11	0.464	305	145	352	2710	113	
988	350	1148	534	0.852	9.02	0.386	210	127	304	2360	100	
850	299	977	456	0.850	10.2	0.318	137	110	259	2030	86	
706	246	799	374	0.853	11.9	0.250	80.2	90.4	212	1660	71	
584	201	656	305	0.846	14.1	0.197	47.2	76.4	180	1430	60	
510	174	567	264	0.848	15.8	0.167	31.8	66.3	156	1230	52	
450	152	497	231	0.847	17.7	0.143	22.2	58.7	137	1080	46	
379	130	438	199	0.848	10.1	0.0610	48.8	65.2	120	947	51	152x152
326	110	372	169	0.848	11.5	0.0499	31.7	56.1	102	806	44	
273	91	309	140	0.848	13.3	0.0399	19.2	47.1	84.9	667	37	
222	73	248	112	0.849	16.0	0.0308	10.5	38.3	68.1	536	30	
164	53	182	80	0.840	20.7	0.0212	4.63	29.2	48.4	392	23	

Universal Bearing Piles

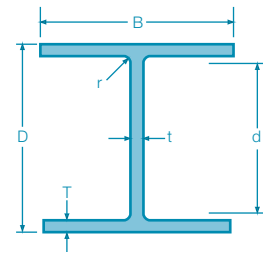

Designation		Mass per metre kg/m	Depth of section D mm	Width of section B mm	Thickness of web t mm	Thickness of flange T mm	Root radius r mm	Depth between fillets d mm	Ratios for local buckling		Second moment of area		Radius of gyration	
Serial size									Flange B/2T	Web d/t	Axis x-x cm ⁴	Axis y-y cm ⁴	Axis x-x cm	Axis y-y cm
356x368	174	173.9	361.4	378.5	20.3	20.4	15.2	290.2	9.28	14.3	51009	18463	15.2	9.13
	152	152.0	356.4	376.0	17.8	17.9	15.2	290.2	10.5	16.3	43972	15877	15.1	9.05
	133	133.0	352.0	373.8	15.6	15.7	15.2	290.2	11.9	18.6	37983	13680	15.0	8.99
	109	108.9	346.4	371.0	12.8	12.9	15.2	290.2	14.4	22.7	30632	10987	14.9	8.90
305x305	223	222.9	337.9	325.7	30.3	30.4	15.2	246.7	5.36	8.14	52699	17577	13.6	7.87
	186	186.0	328.3	320.9	25.5	25.6	15.2	246.7	6.27	9.67	42610	14143	13.4	7.73
	149	149.1	318.5	316.0	20.6	20.7	15.2	246.7	7.63	12.0	33067	10910	13.2	7.58
	126	126.1	312.3	312.9	17.5	17.6	15.2	246.7	8.89	14.1	27408	9002	13.1	7.49
	110	110.0	307.9	310.7	15.3	15.4	15.2	246.7	10.1	16.1	23563	7709	13.0	7.42
	95	94.9	303.7	308.7	13.3	13.3	15.2	246.7	11.6	18.5	20045	6529	12.9	7.35
	88	88.0	301.7	307.8	12.4	12.3	15.2	246.7	12.5	19.9	18425	5984	12.8	7.31
	79	78.9	299.3	306.4	11.0	11.1	15.2	246.7	13.8	22.4	16444	5326	12.8	7.28
254x254	85	85.1	254.3	260.4	14.4	14.3	12.7	200.3	9.10	13.9	12284	4215	10.6	6.24
	71	71.0	249.7	258.0	12.0	12.0	12.7	200.3	10.8	16.7	10071	3439	10.6	6.17
	63	63.0	247.1	256.6	10.6	10.7	12.7	200.3	12.0	18.9	8860	3016	10.5	6.13
203x203	54	53.9	204.0	207.7	11.3	11.4	10.2	160.8	9.11	14.2	5027	1705	8.55	4.98
	45	44.9	200.2	205.9	9.5	9.5	10.2	160.8	10.8	16.9	4100	1384	8.46	4.92

Dimensions and properties to BS4-1:2005.

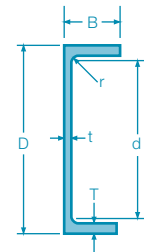

Parallel Flange Channels

Designation		Mass per metre kg/m	Depth of section D mm	Width of section B mm	Thickness of web t mm	Thickness of flange T mm	Distance of Cy cm	Root radius r mm	Depth between fillets d mm	Ratios for local buckling		Second moment of area	
Serial size										Flange B/T	Web d/t	Axis x-x cm ⁴	Axis y-y cm ⁴
430x100	64	64.4	430	100	11.0	19.0	2.62	15	362	5.26	32.9	21939	722
380x100	54	54.0	380	100	9.5	17.5	2.79	15	315	5.71	33.2	15034	643
300x100	46	45.5	300	100	9.0	16.5	3.05	15	237	6.06	26.3	8229	568
300x90	41	41.4	300	90	9.0	15.5	2.60	12	245	5.81	27.2	7218	404
260x90	35	34.8	260	90	8.0	14.0	2.74	12	208	6.43	26.0	4728	353
260x75	28	27.6	260	75	7.0	12.0	2.10	12	212	6.25	30.3	3619	185
230x90	32	32.2	230	90	7.5	14.0	2.92	12	178	6.43	23.7	3518	334
230x75	26	25.7	230	75	6.5	12.5	2.30	12	181	6.00	27.8	2748	181
200x90	30	29.7	200	90	7.0	14.0	3.12	12	148	6.43	21.1	2523	314
200x75	23	23.4	200	75	6.0	12.5	2.48	12	151	6.00	25.2	1963	170
180x90	26	26.1	180	90	6.5	12.5	3.17	12	131	7.20	20.2	1817	277
180x75	20	20.3	180	75	6.0	10.5	2.41	12	135	7.14	22.5	1370	146
150x90	24	23.9	150	90	6.5	12.0	3.30	12	102	7.50	15.7	1162	253
150x75	18	17.9	150	75	5.5	10.0	2.58	12	106	7.50	19.3	861	131
125x65	15	14.8	125	65	5.5	9.5	2.25	12	82	6.84	14.9	483	80.0
100x50	10	10.2	100	50	5.0	8.5	1.73	9	65	5.88	13.0	208	32.3

Dimensions and properties to BS4-1:2005.

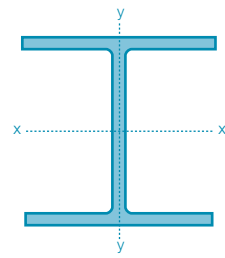

Elastic modulus		Plastic modulus		Buckling parameter	Torsional index	Warping constant	Torsional constant	Area of section	Indicative Pcy values for S275 steel for $L_e=3.5m$	Designation
Axis x-x	Axis y-y	Axis x-x	Axis y-y	u	x	H	J	cm ²	kN	Serial size
cm ³	cm ³	cm ³	cm ³			dm ⁶	cm ⁴			
2823	976	3186	1497	0.821	15.8	5.37	330	221	5150	174 356x368
2468	845	2767	1293	0.821	17.8	4.55	223	194	4510	152
2158	732	2406	1118	0.822	20.1	3.87	151	169	4060	133
1769	592	1956	903	0.823	24.2	3.05	84.6	139	3330	109
3119	1079	3653	1680	0.826	9.55	4.15	943	284	6330	223 305x305
2596	881	3003	1366	0.827	11.1	3.24	560	237	5250	186
2076	691	2370	1065	0.828	13.5	2.42	295	190	4180	149
1755	575	1986	885	0.829	15.7	1.95	182	161	3520	126
1531	496	1720	762	0.830	17.7	1.65	122	140	3160	110
1320	423	1475	648	0.830	20.2	1.38	80.0	121	2720	95
1221	389	1361	595	0.830	21.6	1.25	64.2	112	2510	88
1099	348	1218	531	0.832	23.9	1.11	46.9	100	2240	79
966	324	1092	498	0.825	15.6	0.607	81.8	108	2250	85 254x254
807	267	904	409	0.826	18.4	0.486	48.4	90.4	1880	71
717	235	799	360	0.827	20.5	0.421	34.3	80.2	1660	63
493	164	557	252	0.827	15.8	0.158	32.7	68.7	1240	54 203x203
410	134	459	206	0.827	18.6	0.126	19.2	57.2	1020	45

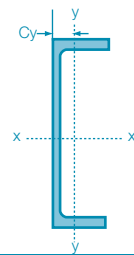

Radius of gyration	Elastic modulus		Plastic modulus		Buckling parameter	Torsional index	Warping constant	Torsional constant	Area of section	Indicative values for S275 steel for $L_e=3.5m$		Designation	
Axis x-x	Axis y-y	Axis x-x	Axis y-y	Axis x-x	Axis y-y	u	H	J	cm ²	Mcx	Pcy	Serial size	
cm	cm	cm ³	cm ³	cm ³	cm ³		dm ⁶	cm ⁴		kNm	kN		
16.3	2.97	1020	97.9	1222	176	0.917	22.5	0.219	63.0	82.1	324	807	64 430x100
14.8	3.06	791	89.2	933	161	0.932	21.2	0.150	45.7	68.7	247	705	54 380x100
11.9	3.13	549	81.7	641	148	0.944	17.0	0.0813	36.8	58.0	170	614	46 300x100
11.7	2.77	481	63.1	568	114	0.934	18.4	0.0581	28.8	52.7	156	473	41 300x90
10.3	2.82	364	56.3	425	102	0.942	17.2	0.0379	20.6	44.4	117	410	35 260x90
10.1	2.30	278	34.4	328	62.0	0.932	20.5	0.0203	11.7	35.1	90.2	234	28 260x75
9.27	2.86	306	55.0	355	99.2	0.950	15.1	0.0279	19.3	41.0	97.6	387	32 230x90
9.17	2.35	239	34.8	278	63.2	0.947	17.3	0.0153	11.8	32.7	76.6	226	26 230x75
8.16	2.88	252	53.4	291	94.6	0.954	12.9	0.0197	18.3	37.9	80.1	361	30 200x90
8.11	2.39	196	33.8	227	60.8	0.956	14.8	0.0107	11.1	29.9	62.4	212	23 200x75
7.40	2.89	202	47.4	232	83.5	0.949	12.8	0.0141	13.3	33.2	63.8	318	26 180x90
7.27	2.38	152	28.8	176	52.0	0.946	15.3	0.0075	7.34	25.9	48.5	183	20 180x75
6.18	2.89	155	44.4	179	77.0	0.936	10.8	0.0089	11.8	30.4	49.1	291	24 150x90
6.15	2.40	115	26.6	132	47.3	0.946	13.1	0.0047	6.10	22.8	36.3	163	18 150x75
5.07	2.06	77.3	18.8	89.9	33.5	0.942	11.1	0.0019	4.72	18.8	24.7	104	15 125x65
4.00	1.58	41.5	9.9	48.9	17.6	0.942	10.0	0.0005	2.53	13.0	13.4	44.9	10 100x50

ASB (Asymmetric Slimflor® Beams)

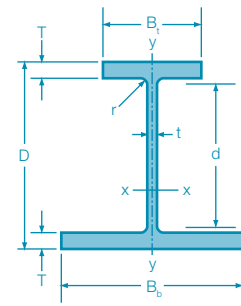

Designation		Mass per metre kg/m	Depth of section D mm	Width of top flange B _t mm	Width of bottom flange B _b mm	Thickness of web t mm	Thickness of flange T mm	Root radius r mm	Depth between fillets d mm	Ratios for local buckling			Elastic neutral axis position y _e cm	Second moment of area	
Serial size	Top flange B _t /2T									Bottom flange B _b /2T	Web d/t	Axis x-x cm ⁴		Axis y-y cm ⁴	
300ASB	249*	249.2	342	203	313	40	40	27	208	2.54	3.91	5.20	19.2	52920	13194
	196	195.5	342	183	293	20	40	27	208	2.29	3.66	10.4	19.8	45871	10463
	185*	184.6	320	195	305	32	29	27	208	3.36	5.26	6.50	18.0	35657	8752
	155	155.4	326	179	289	16	32	27	208	2.80	4.52	13.0	18.9	34514	7989
	153*	152.8	310	190	300	27	24	27	208	3.96	6.25	7.70	17.4	28398	6840
280ASB	136*	136.4	288	190	300	25	22	24	196	4.32	6.82	7.84	16.3	22216	6256
	124	123.9	296	178	288	13	26	24	196	3.42	5.54	15.1	17.2	23453	6410
	105	104.7	288	176	286	11	22	24	196	4.00	6.50	17.8	16.8	19249	5298
	100*	100.3	276	184	294	19	16	24	196	5.75	9.19	10.3	15.6	15506	4245
	74	73.6	272	175	285	10	14	24	196	6.25	10.2	19.6	15.7	12191	3334

For further information see the 'Slimdek® – Engineered flooring solution' brochure or refer to the contact details on page 26. Free design software is available. The elastic and plastic neutral axis positions are measured from the upper surface of the beam.

*These sections have been specially developed with thicker webs for improved performance in fire.

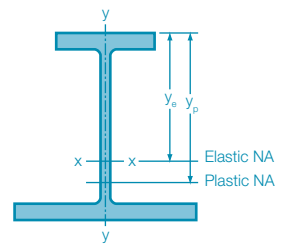

Elastic modulus			Radius of gyration		Plastic neutral axis position	Plastic modulus		Buckling parameter	Torsional index	Warping constant	Torsional constant	Area of section	Designation
Axis x-x top	Axis x-x bottom	Axis y-y	Axis x-x	Axis y-y	y_p	Axis x-x	Axis y-y	u	x	H	J	cm ²	Serial size
cm ³	cm ³	cm ³	cm	cm	cm	cm ³	cm ³			dm ³	cm ⁴		
2757	3528	843	12.9	6.45	22.6	3761	1512	0.825	6.80	2.00	2004	317	249* 300ASB
2321	3185	714	13.6	6.48	28.1	3055	1229	0.845	7.86	1.50	1177	249	196
1984	2547	574	12.3	6.10	21.0	2658	1030	0.822	8.56	1.20	871	235	185*
1825	2519	553	13.2	6.35	27.3	2361	949	0.843	9.40	1.07	620	198	155
1628	2088	456	12.1	5.93	20.4	2160	816	0.822	9.97	0.895	513	195	153*
1367	1777	417	11.3	6.00	19.2	1806	740	0.814	10.2	0.710	379	174	136* 280ASB
1360	1891	445	12.2	6.37	25.8	1730	761	0.832	10.5	0.721	332	158	124
1145	1604	370	12.0	6.30	25.4	1441	632	0.831	12.1	0.574	207	133	105
995	1292	289	11.0	5.76	18.4	1295	510	0.815	13.1	0.451	160	128	100*
776	1060	234	11.4	5.96	21.3	979	402	0.830	16.6	0.338	72.2	93.7	74

Angles

Equal Angles

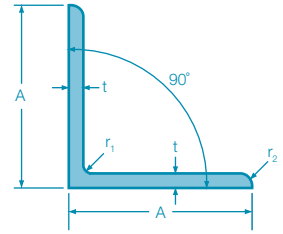

Designation			Mass per metre kg/m	Root radius r_1 mm	Toe radius r_2 mm	Area of section cm ²	Distance to centre of gravity C cm	Second moment of area		
Serial size A x A mm x mm	Thickness t mm	Axis x-x, y-y cm ⁴						Axis u-u cm ⁴	Axis v-v cm ⁴	
200x200	24	71.1	18	9.0	90.6	5.84	3331	5280	1380	
	20	59.9	18	9.0	76.3	5.68	2851	4530	1170	
	18	54.2	18	9.0	69.1	5.60	2600	4150	1050	
	16	48.5	18	9.0	61.8	5.52	2342	3720	960	
➤ 150x150	18	40.1	16	8.0	51.0	4.37	1050	1680	440	
	15	33.8	16	8.0	43.0	4.25	898	1430	370	
	12	27.3	16	8.0	34.8	4.12	737	1170	303	
	10	23.0	16	8.0	29.3	4.03	624	990	258	
➤ 120x120	15	26.6	13	6.5	33.9	3.51	445	710	186	
	12	21.6	13	6.5	27.5	3.40	368	584	152	
	10	18.2	13	6.5	23.2	3.31	313	497	129	
	8	14.7	13	6.5	18.7	3.23	256	411	107	
➤ 100x100	15	21.9	12	6.0	27.9	3.02	249	395	105	
	12	17.8	12	6.0	22.7	2.90	207	328	85.7	
	10	15.0	12	6.0	19.2	2.82	177	280	73.0	
	8	12.2	12	6.0	15.5	2.74	145	230	59.9	
➤ 90x90	12	15.9	11	5.5	20.3	2.66	148	235	62.0	
	10	13.4	11	5.5	17.1	2.58	127	201	52.6	
	8	10.9	11	5.5	13.9	2.50	104	166	43.1	
	7	9.6	11	5.5	12.2	2.45	92.6	147	38.3	

Dimensions and properties to BS EN 10056-1:1999.

➤ These dimensions are in addition to our standard range to the BS EN 10056-1:1999 specification.

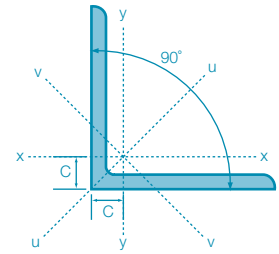

Axis x-x, y-y cm	Radius of gyration		Elastic modulus Axis x-x, y-y cm ³	Torsional constant J cm ⁴	Equivalent slenderness coefficient ϕ_a	Indicative P _{cy} values for S275 steel for L _e =3.5m kN	Designation	
	Axis u-u cm	Axis v-v cm					Thickness t mm	Serial size A x A mm x mm
6.06	7.64	3.90	235	182	2.50	1460	24	200x200
6.11	7.70	3.92	199	107	3.05	1240	20	
6.13	7.75	3.90	181	78.9	3.43	1120	18	
6.16	7.76	3.94	162	56.1	3.85	974	16	
4.54	5.73	2.92	98.8	58.6	2.48	617	18	150x150
4.57	5.76	2.93	83.5	34.6	3.01	528	15	
4.60	5.80	2.95	67.8	18.2	3.77	413	12	
4.62	5.82	2.97	56.9	10.8	4.51	282	10	
3.62	4.57	2.34	52.4	27.0	2.37	302	15	120x120
3.65	4.60	2.35	42.7	14.2	2.99	246	12	
3.67	4.63	2.36	36.0	8.41	3.61	209	10	
3.69	4.67	2.38	29.1	4.44	4.56	141	8	
2.98	3.76	1.94	35.6	22.3	1.92	184	15	100x100
3.02	3.80	1.94	29.1	11.8	2.44	149	12	
3.04	3.83	1.95	24.6	6.97	2.94	127	10	
3.06	3.85	1.96	20.0	3.68	3.70	101	8	
2.70	3.40	1.75	23.4	10.46	2.17	112	12	90x90
2.72	3.42	1.75	19.8	6.20	2.64	94.4	10	
2.74	3.45	1.76	16.1	3.28	3.33	77.5	8	
2.75	3.46	1.77	14.1	2.24	3.80	66.3	7	

Angles

Unequal Angles

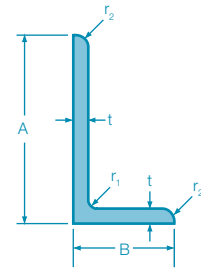

Designation						Distance to centre of gravity		Second moment of area			
Serial size A x B mm x mm	Thickness t mm	Mass per metre kg/m	Root radius r ₁ mm	Toe radius r ₂ mm	Area of section cm ²	C _x cm	C _y cm	Axis x-x cm ⁴	Axis y-y cm ⁴	Axis u-u cm ⁴	Axis v-v cm ⁴
▶ 200x150	18	47.1	15	7.5	60.0	6.33	3.85	2376	1146	2920	623
	15	39.6	15	7.5	50.5	6.21	3.73	2023	979	2480	526
	12	32.0	15	7.5	40.8	6.08	3.61	1653	803	2030	430
200x100	15	33.7	15	7.5	43.0	7.16	2.22	1759	299	1860	193
	12	27.3	15	7.5	34.8	7.03	2.10	1441	247	1530	159
	10	23.0	15	7.5	29.2	6.93	2.01	1219	210	1290	135
150x90	15	26.6	12	6.0	33.9	5.21	2.23	761	205	841	126
	12	21.6	12	6.0	27.5	5.08	2.12	627	171	694	104
	10	18.2	12	6.0	23.2	5.00	2.04	533	146	591	88.3
150x75	15	24.8	12	6.0	31.7	5.52	1.81	713	119	753	78.6
	12	20.2	12	6.0	25.7	5.40	1.69	589	99.6	623	64.7
	10	17.0	12	6.0	21.7	5.31	1.61	501	85.4	531	55.1
125x75	12	17.8	11	5.5	22.7	4.31	1.84	354	95.5	391	58.5
	10	15.0	11	5.5	19.1	4.23	1.76	302	82.1	334	49.9
	8	12.2	11	5.5	15.5	4.14	1.68	247	67.6	274	40.9
100x75	12	15.4	10	5.0	19.7	3.27	2.03	189	90.2	230	49.5
	10	13.0	10	5.0	16.6	3.19	1.95	162	77.6	197	42.2
	8	10.6	10	5.0	13.5	3.10	1.87	133	64.1	162	34.6
▶ 100x65	10	12.3	10	5.0	15.6	3.36	1.63	154	51.0	175	30.1
▶ 8	9.9	10	5.0	12.7	12.7	3.27	1.55	127	42.2	144	24.8
▶ 7	8.8	10	5.0	11.2	11.2	3.23	1.51	113	37.6	128	22.0

Dimensions and properties to BS EN 10056-1:1999.

▶ These dimensions are in addition to our standard range to the BS EN 10056-1:1999 specification.

* Sections in italics may become slender under axial compression.

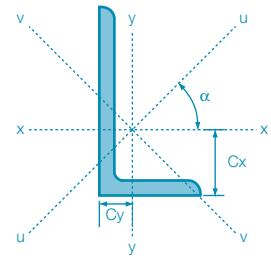

Axis x-x cm	Radius of gyration			Angle Axis x-x to axis u-u $\tan \alpha$	Elastic modulus		Torsional constant J cm ⁴	Equivalent slenderness coefficient		Mono- symmetry index ψ_a	Indicative P_{cy}^* values for S275 steel for $L_e=3.5m$ kN	Designation	
	Axis y-y cm	Axis u-u cm	Axis v-v cm		Axis x-x cm ²	Axis y-y cm ²		Min. ϕ_a	Max. ϕ_a			Thickness t mm	Serial size A x B mm x mm
6.29	4.37	6.97	3.22	0.549	174	103	67.9	2.93	3.72	4.60	813	18 15 12	200x150
6.33	4.40	7.00	3.23	0.551	147	86.9	39.9	3.53	4.50	5.55	700		
6.36	4.44	7.04	3.25	0.552	119	70.5	20.9	4.43	5.70	6.97	445		
6.40	2.64	6.59	2.12	0.260	137	38.4	34.3	3.54	5.17	9.19	327	15 12 10	200x100
6.43	2.67	6.63	2.14	0.262	111	31.3	18.0	4.42	6.57	11.5	250		
6.46	2.68	6.65	2.15	0.263	93.3	26.3	10.7	5.26	7.92	13.9	179		
4.74	2.46	4.98	1.93	0.354	77.7	30.4	26.8	2.58	3.59	5.96	221	15 12 10	150x90
4.78	2.49	5.02	1.94	0.358	63.3	24.8	14.1	3.24	4.58	7.50	181		
4.80	2.51	5.05	1.95	0.360	53.3	21.0	8.30	3.89	5.56	9.03	154		
4.75	1.94	4.88	1.58	0.253	75.2	21.0	25.1	2.62	3.74	6.84	147	15 12 10	150x75
4.78	1.97	4.92	1.59	0.258	61.3	17.1	13.2	3.30	4.79	8.60	120		
4.81	1.99	4.95	1.60	0.261	51.7	14.5	7.8	3.95	5.83	10.4	103		
3.95	2.05	4.15	1.61	0.354	43.2	16.9	11.6	2.66	3.73	6.23	108	12 10 8	125x75
3.97	2.07	4.18	1.61	0.357	36.5	14.3	6.87	3.21	4.55	7.50	91.2		
4.00	2.09	4.21	1.63	0.360	29.6	11.6	3.62	4.00	5.75	9.43	74.3		
3.10	2.14	3.42	1.59	0.540	28.1	16.5	10.0	2.10	2.64	3.46	92.1	12 10 8	100x75
3.12	2.16	3.45	1.59	0.544	23.8	14.0	5.95	2.54	3.22	4.17	77.6		
3.14	2.18	3.47	1.60	0.547	19.3	11.4	3.13	3.18	4.08	5.24	63.8		
3.14	1.81	3.35	1.39	0.410	23.2	10.5	5.61	2.52	3.43	5.45	57.4	10 8 7	100x65
3.16	1.83	3.37	1.40	0.413	18.9	8.54	2.96	3.14	4.35	6.86	47.3		
3.17	1.83	3.39	1.40	0.415	16.6	7.53	2.02	3.58	5.00	7.85	41.7		

Product specifications/tolerances

The dimensions and mass of the following hot-rolled structural steel sections currently produced by Corus – Universal Beams, Universal Columns, Universal Bearing Piles and Parallel Flange Channels – are specified in BS4-1:2005.

Rolling tolerances – BS EN 10034:1993

This European Standard specifies tolerances on shape, dimensions and mass of structural steel universal beams, columns and bearing piles.

Section height (*h*)

The deviation from nominal on section height measured at the centre line of web thickness shall be within the tolerance given in Table 1(a).

Table 1 (a) Tolerance on height and cross-section

Section height <i>h</i> mm	Tolerance mm
Up to and including 180	+3.0 -2.0
Greater than 180 up to and including 400	+4.0 -2.0
Greater than 400 up to and including 700	+5.0 -3.0
Greater than 700	±5.0

Flange width (*b*)

The deviation from nominal on flange width shall be within the tolerance given in Table 1(b).

Table 1 (b) Tolerance on flange widths

Flange width <i>b</i> mm	Tolerance mm
Up to and including 110	+4.0 -1.0
Greater than 110 up to and including 210	+4.0 -2.0
Greater than 210 up to and including 325	±4.0
Greater than 325	+6.0 -5.0

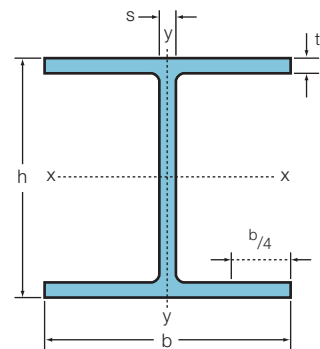

t^* is measured at $b/4$

Web thickness (s)

The deviation from nominal on web thickness measured at the mid-point of dimension (h) shall be within the tolerance given in Table 1(c).

Table 1 (c) Tolerances on web thickness	
Web thickness s mm	Tolerance mm
Less than 7	±0.7
7 up to but excluding 10	±1.0
10 up to but excluding 20	±1.5
20 up to but excluding 40	±2.0
40 up to but excluding 60	±2.5
60 and over	±3.0

Flange thickness (t)

The deviation from nominal on flange thickness measured at the quarter flange width point shall be within the tolerance given in Table 1(d).

Table 1 (d) Tolerances on flange thickness	
Flange thickness t mm	Tolerance mm
Less than 6.5	+1.5
	-0.5
6.5 up to but excluding 10	+2.0
	-1.0
10 up to but excluding 20	+2.5
	-1.5
20 up to but excluding 30	+2.5
	-2.0
30 up to but excluding 40	±2.5
40 up to but excluding 60	±3.0
60 and over	±4.0

Rolling tolerances – BS EN 10034:1993

Out-of-squareness ($k + k'$)

The out-of-squareness of the section shall not exceed the maximum given in Table 2(a).

Web off-centre (e)

The mid-thickness of the web shall not deviate from the mid-width position on the flange by more than the distance (e) given in Table 2(b).

Table 2 (a) Tolerance on out-of-squareness of universal beams, columns and bearing piles

Flange width b mm	Tolerance mm
Up to and including 110	1.5
Greater than 110	2% of b (maximum 6.5mm)

Table 2 (b) Tolerance on web off-centre of universal beams, columns and bearing piles

Flange thickness t mm	Flange width b mm	Web off-centre where $e = \frac{b_1 - b_2}{2}$ mm
$t < 40$	Up to and including 110	2.5
	Greater than 110 up to and including 325	3.5
	Greater than 325	5.0
$t \geq 40$	Greater than 110 up to and including 325	5.0
	Greater than 325	8.0

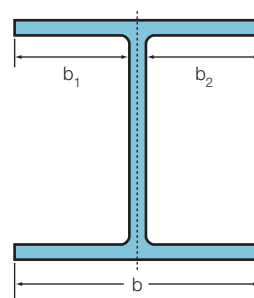
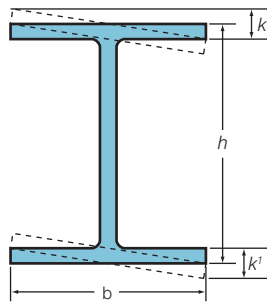
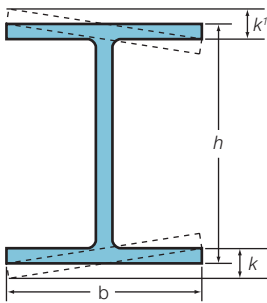

Straightness (q_{xx} or q_{yy})

The straightness shall comply with the requirements given in Table 3.

Table 3 Tolerance on straightness of universal beams, columns and bearing piles

Section height h mm	Tolerance q_{xx} and q_{yy} on length L %
Greater than 80 up to and including 180	0.30 L
Greater than 180 up to and including 360	0.15 L
Greater than 360	0.1 L

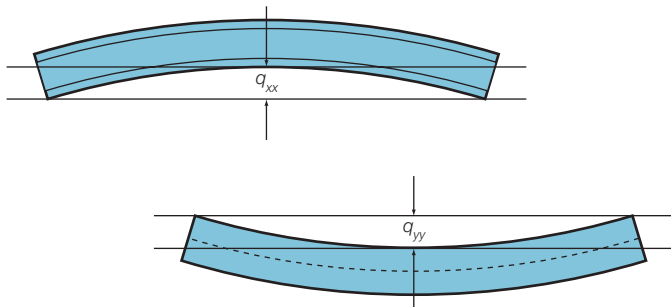

Tolerance on mass

The deviation from the nominal mass of a batch or a piece shall not exceed $\pm 4.0\%$.

The mass deviation is the difference between the actual mass of the batch or piece and the calculated mass. The calculated mass shall be determined using a density of 7850kg/m^3 .

Tolerance on length

The sections shall be cut to ordered lengths to tolerances of:

- a) $\pm 50\text{mm}$
- or
- b) $-0, +100\text{mm}$ where minimum lengths are required.

L represents the longest useable length of the section assuming that the ends of the section have been cut square.

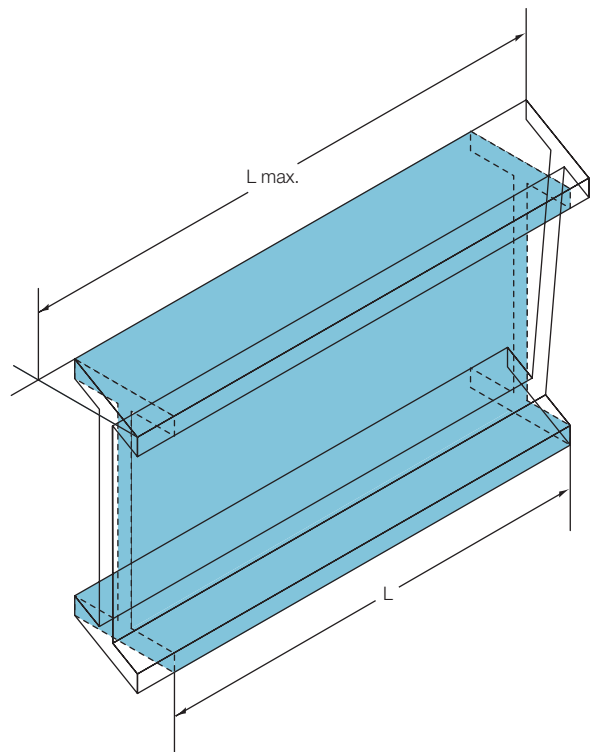

Rolling tolerances – BS EN 10056-2:1993

This European Standard specifies tolerances on shape, dimensions and mass of hot-rolled structural steel equal and unequal leg angles.

Leg length (a or b)

The deviation from nominal on leg length shall be within the tolerance given in Table 1(a). For unequal leg angles the longer leg length (a) shall be used to determine the tolerance band.

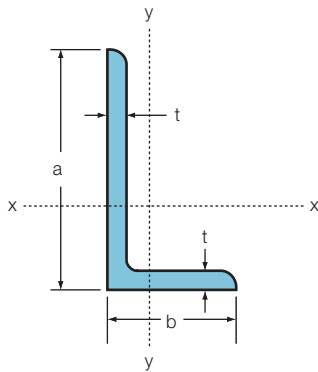

Table 1 (a) Dimensional tolerances	
Leg length a mm	Tolerance mm
Up to and including 50	±1.0
Greater than 50 up to and including 100	±2.0
Greater than 100 up to and including 150	±3.0
Greater than 150 up to and including 200	±4.0
Greater than 200	+6.0 -4.0

Section thickness (t)

The deviation from nominal on thickness shall be within the tolerances given in Table 1(b).

Table 1 (b) Thickness tolerances	
Section thickness t mm	Tolerance mm
Up to and including 5	±0.50
Greater than 5 up to and including 10	±0.75
Greater than 10 up to and including 15	±1.0
Greater than 15	±1.20

Web out-of-square (k)

Out-of-squareness of the section shall not exceed the maximum given in Table 1(c). For unequal leg angles, the longer leg length (a) shall be used to determine the tolerance band.

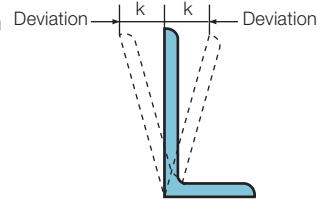

Table 1 (c) Squareness tolerances	
Out of square – Leg length mm	Tolerance mm
Up to and including 100	1.0
Greater than 100 up to and including 150	1.5
Greater than 150 up to and including 200	2.0
Greater than 200	3.0

Straightness (q)

The deviation from straightness shall not exceed the tolerances given in Table 1(d). For unequal leg angles, the longer leg length (a) shall be used to determine the tolerance band.

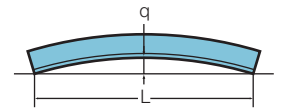

Table 1 (d) Straightness tolerances			
Leg length a mm	Tolerance over full bar length Deviation q mm	Tolerance over any part bar length	
		Length considered mm	Deviation q mm
Up to and including 150	0.4% L	1,500	6.0
Up to and including 250	0.2% L	2,000	3.0
Greater than 200	0.1% L	3,000	3.0

Tolerance on mass

The deviation from the nominal mass of any individual piece shall not exceed:

- a) ±6% for thickness for $t \leq 4\text{mm}$ or
- b) ±4% for thickness for $t > 4\text{mm}$.

The deviation from the nominal mass is the difference between the actual mass of the piece and the calculated mass. The calculated mass shall be determined using a density of 7850kg/m^3 .

Tolerance on length

The tolerance on ordered length shall be either:

- a) ±50mm; or
- b) -0, +100mm where minimum lengths are required.

Rolling tolerances – BS EN 10279:2000

This European Standard specifies requirements for the tolerances on dimensions, shape and mass of hot-rolled steel channels with parallel flanges.

Table 1: Tolerances for parallel flange channels

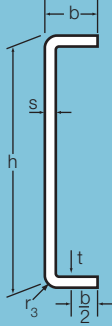
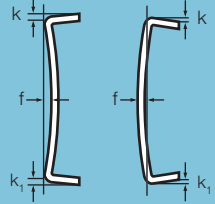
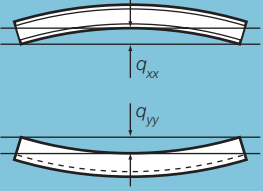
Designation	Property mm	Range mm	Tolerance mm
	Height h	h ≤ 65 65 < h ≤ 200 200 < h ≤ 400 400 < h	±1.5 ±2.0 ±3.0 ±4.0
	Flange width b	b ≤ 50 50 < b ≤ 100 100 < b ≤ 125 125 < b	±1.5 ±2.0 ±2.5 ±3.0
	Web thickness s	s ≤ 10 10 < s ≤ 15 15 < s	±0.5 ±0.7 ±1.0
	Flange thickness t	t ≤ 10 10 < t ≤ 15 15 < t	-0.5* -1.0* -1.5*
	Heel radius r _s	All sizes	≤ -0.3t
		Out of squareness k+k ₁	b ≤ 100 100 < b
Web flatness f		h ≤ 100 100 < h ≤ 200 200 < h ≤ 400 400 < h	±0.5 ±1.0 ±1.5 ±1.5
		Straightness q _{xx}	h ≤ 150 150 < h ≤ 300 300 < h
	q _{yy}	h ≤ 150 150 < h ≤ 300 300 < h	±0.5% of L ±0.3% of L ±0.2% of L
	Standard Alternative standard (by agreement)	Length (L) Length (L)	All All
Mass per unit length	kg/m	h ≤ 125 125 < h	±6% ±4%

* Plus tolerances are limited by weight

Offices and agents for Corus products

Europe

Czech Republic

Corus International
4th Floor, Mala Stepanska 9
Praha 2 - 120 00
Czech Republic
T: +420 2 2491 9545
F: +420 2 2491 9546
jan.blazek@corusgroup.com

Denmark

Corus International
Kongevejen 71
PO Box 113
DK-2840 Holte
Denmark
T: +45 39 960900
F: +45 39 960949
denmark@corusgroup.com

Finland

Corus International
Hitsaajankatu 22
00810 Helsinki
Finland
T: +358 9 4542450
F: +358 9 45424520
helsinki@corusgroup.com

France

Corus International
Parc St Exupéry
9 Rue Maryse Bastié
69500 Bron
France
T: +33 (0) 4 7214 8620
F: +33 (0) 4 7841 1994
lyon@corusgroup.com

Corus International
3 Allée des Barbanniers
92632 Gennevilliers Cedex
France
T: +33 (0) 1414 73319
F: +33 (0) 1412 19475
paris@corusgroup.com

Germany

Corus International
Am Trippelsberg 48
40589 Düsseldorf
Germany
T: +49 211 4926-0
F: +49 211 4926-282
dusseldorf@corusgroup.com

Hungary

Corus Hungary Kft.
2040 Budaörs, Szabadság u. 117.
Budapest
Hungary
T: +36 23 507 280
hungary@corusgroup.com

Ireland

Corus International
Leeson Court,
88 Lower Leeson Street
Dublin 2
Ireland
T: +353 1 6616773
F: +353 1 6765413
dublin@corusgroup.com

Italy

Corus International
Via Rondoni 1
20146 Milano
Italy
T: +39 02 4225541
F: +39 02 6595007
milan@corusgroup.com

Netherlands

Corus International
Ankerkade 71
6222NL Maastricht
Netherlands
T: +31 (0) 43 4079 292
F: +31 (0) 43 4079 299
benelux@corusgroup.com

Norway

Corus International
Karoline Kristiansens vei 5
0661 Oslo
Norway
T: +47 22 52 69 70
F: +47 22 52 34 11
oslo@corusgroup.com

Poland

Corus International
ul. Piastowska 7
40-005 Katowice
Poland
T: +48 32 6083510
T: +48 32 6083511
F: +48 32 6083502
office@corus.pl

Portugal

Corus International
Sucursal de Portugal
Av. Miguel Bombarda, NR. 36 / 8 I
1050-165 Lisboa
Portugal
T: +351 217 817 040
F: +351 217 817 049
lisbon@corusgroup.com

Spain

Corus International
Rosario Pino 14-16
Torre Rioja
28020 Madrid
Spain
T: +34 91 425 2910
F: +34 91 5790 234
madrid@corusgroup.com

Sweden

Corus International
Amerikahuset
Barlastgatan 2
SE-41463 Gothenburg
Sweden
T: +46 31 779 3200
F: +46 31 779 3228
gothenburg@corusgroup.com

Switzerland

Corus International
Wartenbergstraße 45
Postfach
CH 4020 Basel
Switzerland
T: +41 61 378 98 28
F: +41 61 378 98 29
basel@corusgroup.com

North America

USA

Corus International Americas
Chicago office
475 N. Martingale Road, Suite 400
Schaumburg, IL 60173
United States
T: +1 847 619 0400
or (N America only)
+1 (800) 542-6244
F: +1 847 619 0468
CAI@corusgroup.com

Mexico

Corus International
Ave. Morones Prieto 2805 Pte.
Edif. Torre Guia. 2do. Piso
Col. Lomas de San Francisco
Monterrey
Mexico
T: +52 81 8319 0228
F: +51 81 8319 0227
CAI@corusgroup.com

Far East

China

Corus (Asia) Ltd - Shanghai
Room 2506, K. Wah Centre
1010 Huai Hai Road, Xuhui District
Shanghai 200031
China
T: +86 21 54051616
F: +86 21 54045118
shanghai@corusgroup.com

Hong Kong

Corus International
Unit 2106 - 10, Devon House
979 Kings Road, Quarry Bay,
Hong Kong
Hong Kong Sar
T: +852 2807 0196
F: +852 2807 1805
hong.kong@corusgroup.com

Indonesia

Corus International
Level 11, World Trade Centre
29/31 Jalan Jendral Sudirman
12920 Jakarta
Indonesia
T: +62 21 521 1365
F: +62 21 521 1334
jakarta@corusgroup.com

Japan

Corus International
Room 506, 5th Floor
Ichibancho Central Building
22-1, Ichibancho, Chiyoda Ku
Tokyo 101-0082
Japan
T: +81 3 5215 0445
F: +81 3 5215 0447
tokyo@corusgroup.com

Malaysia

Corus International
Unit 527, 5th Floor, Block A
Damansara Intan
No1 Jalan SS20/27, 47400 Petaling Jaya
Selangor Darul Ehsan
Malaysia
T: +603 7726 9226
F: +603 7726 9227
malaysia@corusgroup.com

Singapore

Corus International
24 Raffles Place
29-05 Clifford Centre
Singapore 59621
Singapore
T: +65 6297 6678
F: +65 6297 6682
singapore@corusgroup.com

South Korea

Corus International
Room No. 1503, 15th Floor,
Dae Il Building
No. 18, Nam Dae Moon Ro-1 Ga
Chung-Gu
Seoul 100-091
Korea - South
T: +822 733 6741/2/3/4
F: +822 733 6745
seoul@corusgroup.com

Taiwan

Corus - Taipei
14th Floor
50 Hsing Sheng South Road
Sec 1
Taipei
Taiwan
T: +886 22 395 4638
F: +886 22 321 8088
taipei@corusgroup.com

Thailand

Corus Metals (Thailand) Ltd
18th Floor, Room 1807,
Q House Asoke Bldg
66 Sukhumvit 21, North Klongtoey
Wattana
Bangkok 10110
Thailand
T: +662 664 2901 - 2903
F: +662 664 2905
thailand@corusgroup.com

Vietnam

Corus Asia Ltd - Vietnam
8/F Jardine House
58 Dong Khoi Street, District 1
Ho Chi Minh City
Vietnam
T: +84 88 222 340
F: +84 88 230 030
vietnam@corusgroup.com

India

Corus International
503/504 Raheja Chambers
213 Backbay Reclamation
Mumbai 400-021
India
T: +91 22 2282 3126
F: +91 22 2287 5148
mumbai@corusgroup.com

Other countries

Australia

Corus International
Factory 4
80/82 Hallam South Road
Hallam
Victoria 3803
Australia
T: +61 3 8795 7833
F: +61 3 8795 7844
melbourne@corusgroup.com

Brazil

Corus International Brazil
Av. das Americas, 4200
Bl, UV - sl. 306
22640-102 - Rio de Janeiro - RJ
Brazil
T: +55 (21) 3385 4004
F: +55 (21) 3385 4581
brazil@corusgroup.com

Chile

Repco Ltda
Casillia 9030, Correo 3
Vina del Mar, Chile
T: +56 32 686667
F: +56 32 978475

Columbia

Georges Raikes Representaciones
Anglo Colombiana (Raikes)
Calle 69 No4-68, Oficina 302
Santafe de Bogota
Columbia
T: +57 15 415708
F: +57 12 103685

Egypt

Corus International
144 El-Urouba Street
Heliopolis
Cairo
Egypt
T: +20 2 418 5655
T: +20 2 414 0211
F: +20 2 418 6116
cairo@corusgroup.com

Libya

Corus International Projects
52 Al-Fatah Tower
Tripoli
Libya
tripoli@corusgroup.com

New Zealand

Corus International
7 Bruce Roderick Drive
East Tamaki 1701, PO Box 58-880
Greenmount 1730
Auckland
New Zealand
T: +64 (0) 927 11780
F: +64 (0) 927 11970
auckland@corusgroup.com

Russia

Corus International
Office 320
Naryshkinskaya Alley 5/2
125 167 Moscow
Russia
T: +7 095 748 3467
F: +7 095 748 3468
moscow@corusgroup.com

Saudi Arabia

Corus UK Ltd (Dammam Branch)
c/o Yusuf bin Ahmed Kanoo
PO Box 37
Dammam 31411
Saudi Arabia
T: +966 3 859 0930
F: +966 3 857 9750
corus.dammam@corusgroup.com

Turkey

Corus Celik Ticaret AS
Asik Kerem Sokak No 30 kat 3
Dikilitas
Besiktas 34349
Istanbul
Turkey
T: +90 212 258 4684
F: +90 212 227 1764
istanbul@corusgroup.com

Ukraine

Corus International
Office 16, Building 11/23B
Chekhivskiy Provvluk
Vorovskoho Street
01 054 Kiev
Ukraine
kiev@corusgroup.com

UAE

Corus - Dubai
Corus Middle East FZE
PO Box 18294
Jebel Ali
Dubai
United Arab Emirates
T: +971 (0) 4 8873 232
F: +971 (0) 4 8873 955
corus.dubai@corusgroup.com

Technical support for the construction industry

Guidance on the design and use of structural steel

We manufacture a wide range of structural sections and plate for building and civil engineering applications and provide free advice to the construction industry on all aspects of design, specification and use.

Our team of qualified engineers have extensive experience and are on hand to give advice on the design and construction of buildings and bridges. We can also give specialist advice on fire engineering, durability and sustainability.

Our network of engineers covers the whole of the UK and Ireland and is supported by a dedicated design team based at our manufacturing centre in Scunthorpe.

If your enquiry is about other products and systems that Corus manufactures, you will be directed to the relevant business or source of expertise.

You can contact us in any of the following ways:

Technical hotline

+44 (0) 1724 405060

Email

construction@corusgroup.com

Website

www.corusconstruction.com

Literature line

+44 (0) 1724 404400

Facsimile

+44 (0) 1724 404224

Address

Corus
Construction Services & Development
PO Box 1
Brigg Road
Scunthorpe
North Lincolnshire
DN16 1BP



www.corusgroup.com

Care has been taken to ensure that this information is accurate, but Corus plc, including its subsidiaries, does not accept responsibility or liability for errors or information which is found to be misleading.

Copyright 2007
Corus

References to British Standards are in respect of the current versions and extracts are quoted by permission of the British Standards Institute from whom copies of the full standards may be obtained.

Corus Construction & Industrial

PO Box 1

Brigg Road

Scunthorpe

North Lincolnshire

DN16 1BP

United Kingdom

T +44(0) 1724 404040

F +44(0) 1724 405600

email: sections@corusgroup.com

www.corusgroup.com

JB:3000 UK06/2007