

# TECHNICAL INFORMATION SHEET

## Anti-slip matting

This Technical Information Sheet highlights the contribution of anti-slip matting to load restraint systems used to restrain steel loads for road transport.

### 1. Specification for anti-slip matting



**Coefficient of friction:** 0.6 (minimum).

**Recommended thickness:** 10mm is suitable for most applications. Thinner matting may not fully isolate the load from the cargo bed. Matting below 8mm will tear too easily when used with steel loads. Matting above 15mm thick may shear when used with steel loads.

**Material:** Typically 1-3mm rubber granulate made from recycled materials and bound with polyurethane elastomer.

**Colour:** Typically black with multicoloured speckling, but may be supplied in a variety of colours.

**Surface texture:** Fine granular texturing.

**Porous / Non-porous:** High level of porosity is desirable.

**Working temperature range:** -20 °C to +100 °C.

**Tensile strength:** 0.6 N/mm<sup>2</sup> minimum.

Anti-slip matting is available as either loose pieces or strips, typically 1m long x 100mm wide.

### 2. How anti-slip matting works

Friction is the resistance of an object to sliding. It is a critical factor in most load restraint systems with its value depending solely on the product weight and surface roughness, and not surface area.

The application of anti-slip matting for the purpose of load restraint increases the friction between adjacent surfaces, for example between the surface of the steel product and the trailer deck.

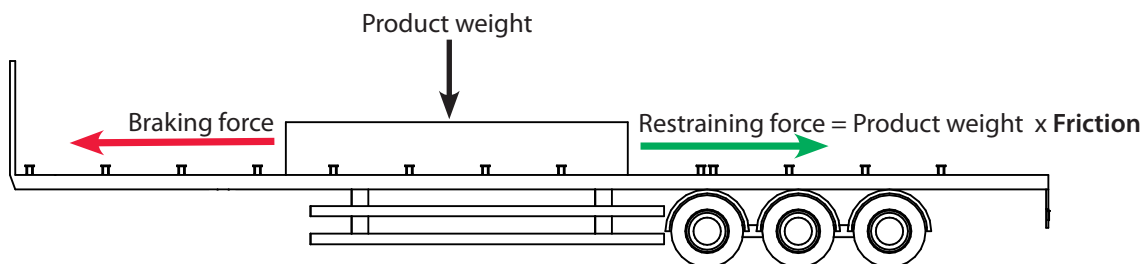

High friction creates more efficient and effective load restraint systems.

Some typical friction coefficients are listed below:

Oiled Steel on Steel = 0.2 (**Low**).

Steel on Wood = 0.4 (**Medium**).

Steel on Anti-Slip Matting = 0.6 (**High**).

# TECHNICAL INFORMATION SHEET

## Anti-slip matting

### 3. Using anti-slip matting

Anti-slip matting may be applied as a whole mat or as loose strips provided that the strips are adequately spaced to effectively prevent steel on steel or steel on wood contact.

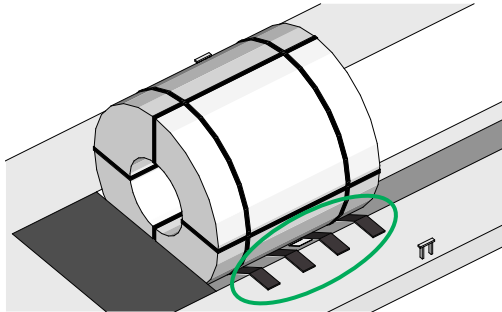

✓ Strips of matting adequately spaced to ensure no contact between the product and the trailer.

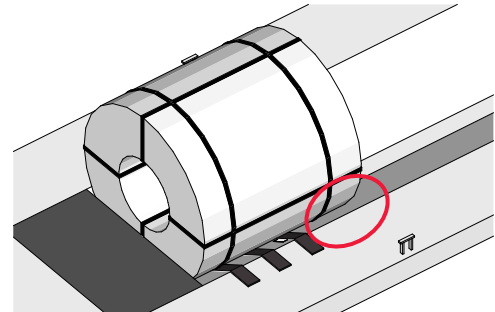

✗ Inadequate and/or poorly positioned anti-slip matting allows product to rest on the trailer bed.

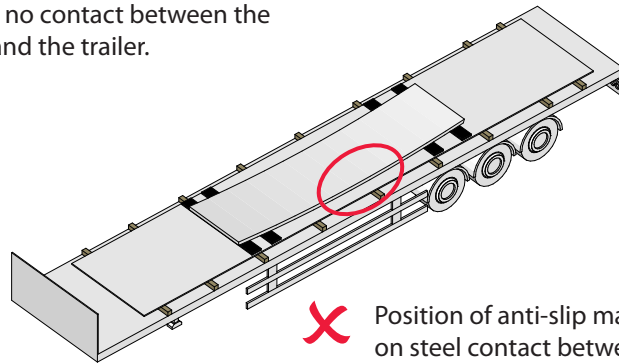

✗ Position of anti-slip matting allows for steel on steel contact between product layers.

Note: It is important to ensure that the anti-slip matting is visible beneath the product for inspection purposes.

### 4. Anti-slip matting on timber bearers

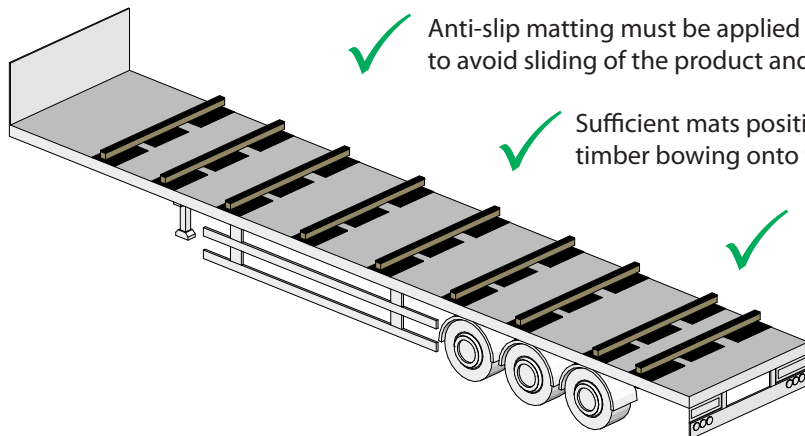

✓ Anti-slip matting must be applied on top and beneath each timber bearer to avoid sliding of the product and timbers across the trailer deck.

✓ Sufficient mats positioned beneath the timber to prevent the timber bowing onto the trailer deck.

✓ Anti-slip matting may be nailed on to the timber bearers or bonded using suitable adhesives.

Note: While the anti-slip matting is applied, it is necessary to avoid dragging the product across the surface of the anti-slip matting as this will cause the mats to become dislodged or torn, rendering them ineffective.

### Warning!

**It is NOT acceptable to use anti-slip matting as a substitute for edge protection.**

**Conveyor belting and other forms of rubber are NOT acceptable alternatives where Load Restraint Guidelines specify anti-slip matting as they have a significantly lower coefficient of friction.**

Care has been taken to ensure that the contents of this publication are accurate, but Tata Steel Europe Limited and its subsidiaries do not accept responsibility or liability for errors or information that is found to be misleading.