

Unlocking the potential of high-strength steel

Ympress® S700MC opens up opportunities for lighter excavator arm designs with equal or better performance

Background

In the earthmoving sector, there is significant development in excavators with regard to performance increase, emission reduction and machine intelligence. Lightweight designs could aid these developments. Tata Steel is expanding its high-strength product range to enable such lightweight designs.

Lightweighting using high-strength steels offers benefits in performance, fuel efficiency and machine transportability. To demonstrate mass-saving potential, Tata Steel engineers used advanced modelling and analysis techniques to re-design an excavator dig-end - focusing on the dipper arm - with the use of high-strength Ympress S700MC.

Excavator dig-ends put high demand on the steel being used. They must have strength to withstand the forces during excavation and they must resist abrasive wear by the material being excavated. At the same time, it is important to minimise the mass of the dipper so that the payload capacity is not compromised or reduced by the weight of the dipper itself. A lighter construction could also allow design freedom to extend reach through a longer arm or, to further reduce counterweight and optimize tail swing design and transportation of the excavator. Ympress S700MC hot-rolled steel delivers improved load-bearing capacity without weight penalties due to its high yield strength (see figure 1).

Mechanical properties

The values shown for the mechanical properties and the bend test apply to test samples parallel to the rolling direction.

	Min. yield strength	Min. tensile strength	Min. elongation after fracture A		Bend radius ¹⁾
	N/mm ²	N/mm ²	%	t < 3mm	t ≥ 3 mm
Ympress S700MC	700	750-950	10	12	2t

¹⁾ Bend test is performed with polished edges, bend line parallel to the rolling direction

Figure 1: The high yield strength of Ympress S700MC improves load-bearing capacity without weight penalties.

Available dimensions of Ympress S700MC

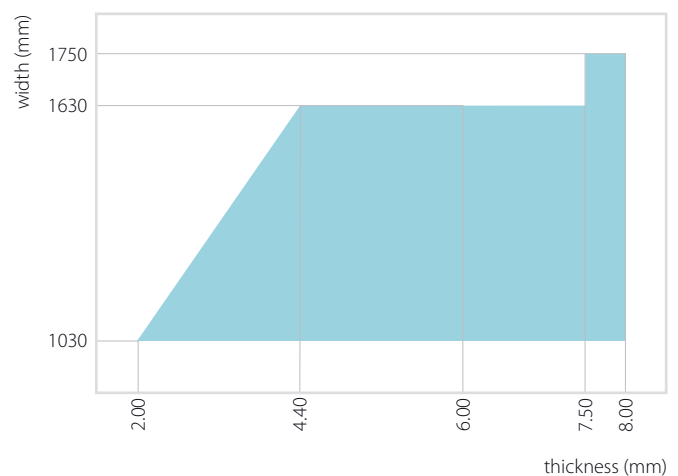

Figure 2: Ympress S700MC is available in a wide range of dimensions for processing flexibility and efficiency. Other dimensions – including increased thickness – are under development. Please enquire if you need material in dimensions outside the window that is currently available.

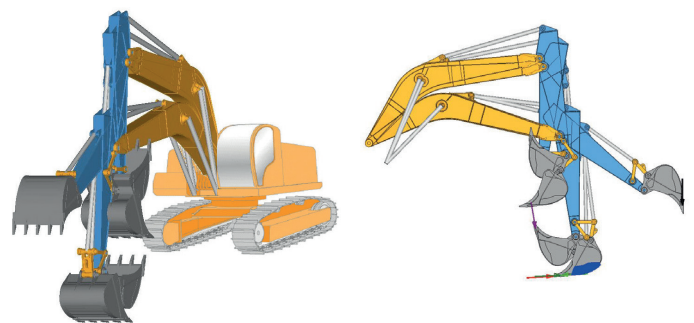

Figure 3: In re-designing the dipper arm, Tata Steel used data from real-life load cases including the forces at play in dig and tamp operations.

Modelling and analysis

Tata Steel engineers modelled an excavator dipper arm in the 20 tonnes excavator class. A conventional excavator dipper geometry was selected as the baseline structure. The baseline material was set at S275JR grade. The aim of the exercise was to optimise the structure weight.

The dipper arm was modelled into segments – with their thickness set as design variables. The original model weight of the dipper is 920kg, of which 645kg is strip steel (see figure 4). The remainder of the weight is in castings, pins and bosses. For optimisation analysis of the dipper, forces were applied at its pins. These forces were extracted from real-life load cases on the whole structure which represented dig, slew, tamp, piercing and lift (see figure 3). Finite element analysis determined the optimum thickness of the strip steel whilst meeting the design requirements for strength and stiffness.

Weight-saving potential

Using computer-aided engineering, gauge optimisation on the excavator dipper arm shows a potential for weight saving of up to 23% on strip steel – with all structural performance requirements being met (see figure 5). As the actual geometry of the structure was unchanged in this study, it is possible that further re-engineering of structure geometry could offer additional weight savings.

	Strip steel weight
Base case	645kg
Optimized case	495kg
Weight saving	23%

Figure 4: Modelling and analysis showed dipper arm weight savings of up to 23% when using high-strength Ympress S700MC.

Cost-saving potential

Applying Ympress S700MC in a re-designed dipper arm offers cost-reduction potential. Total purchasing cost could decrease – with the weight reduction more than compensating for substitution with a premium steel grade. Manufacturing costs could also benefit as lower gauge material reduces weld time and requires less welding filler material.

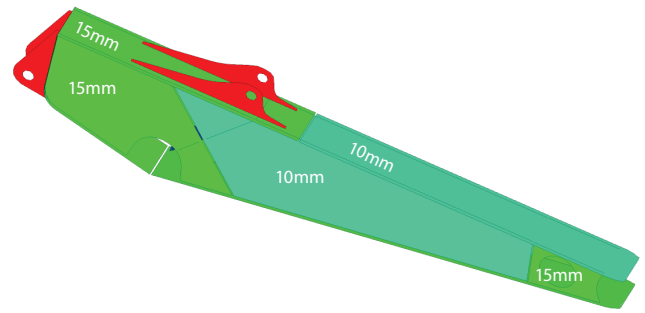

Figure 4: The base-case dipper arm with strip steel segments of grade S275JR up to 15mm – with a total weight of 645kg.

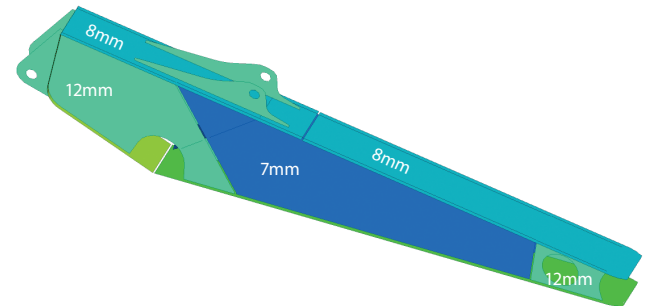

Figure 5: The re-designed lightweight dipper arm with optimized strip steel thickness – allowing potential weight reduction of 23% to 495kg.

Conclusion

The study shows that application of high-strength steels such as Ympress S700MC presents opportunities for lighter, more agile excavator arm designs with equal or better performance. Use of Ympress S700MC in lightweight designs also offers cost-saving potential. Extending this exploratory study to the full dig-end structure would enable identification of increased opportunities to save mass in the boom and optimise performance, tail swing and transportation.

www.tatasteeleurope.com

While care has been taken to ensure that the information contained in this publication is accurate, neither Tata Steel, nor its subsidiaries, accept responsibility or liability for errors or for information which is found to be misleading.

Before using products or services supplied or manufactured by Tata Steel and its subsidiaries, customers should satisfy themselves as to their suitability.

Copyright 2017
Tata Steel Europe Limited

Tata Steel

Engineering

PO Box 10.000

1970 CA IJmuiden

The Netherlands

E: connect.engineering@tatasteel.com

www.tatasteeleurope.com/strip

IN0117:100:EN:1017