



# Provisions for the delivery by ship set out by the Service Center Gelsenkirchen GmbH

As of: December 2014

1. General Safety Regulations and Provisions .....	2
1.1 Introduction .....	2
2. Provisions for Deliveries by Ship .....	3
2.1 Product Regulations .....	3
2.2 Provisions for Unloading .....	3
2.3 Registration .....	5

# 1. General Safety Regulations and Provisions

## 1.1 Introduction

In order to provide a safe working environment for both employees and visitors, the present provisions regarding the delivery and collection were set out by the "Service Center Gelsenkirchen GmbH" (SCG). **Everyone who does not comply with these provisions, will be removed from the company grounds in severe cases.**

## 1.2 General Provisions

It is prohibited to enter with alcoholic beverages or drugs.

It is prohibited for persons under the age of 18 to enter the workshop. Pets must be left in the cabin.

**It is mandatory to wear steel-capped safety boots, a helmet and protective gloves. Entering the workshop without this personal protective equipment is prohibited.**

**The instructions of the SCG personnel responsible for incoming goods must be followed.**

Cranes must only be operated by trained and qualified **SCG** personnel.

Entering other areas and halls of the company grounds than the two registration cabins for outgoing goods, the restrooms in the centre of the workshop and the area in close vicinity of the ship is strictly prohibited!

In the case of disasters, the ship's captain must lock up his ship and go to the assembly point together with the personnel responsible for incoming goods.

Any non-authorized taking of materials and other things is considered theft and will be prosecuted as such.

The ship's captain must familiarize himself with our safety regulations before unloading the cargo.

**It is the SCG personnel for safety reasons forbidden to enter the ship.**

The unloading of the cargo will be carried out according to the instructions of the ship's captain regarding order and load distribution.

Thereafter, at the request of the skipper, the SCG personnel put a container in the cargo area so that the crew can dispose of the dunnage in the container.

**The used wooden dunnage must be free of toxic substances. An acceptance of "fumigated wood" will be expressly refused.**

## 2. Provisions for Deliveries by Ship

### 2.1 Product Regulations

The coils to be delivered must not exceed the following criteria:

1. Maximum weight is **30** tons.
2. Diagonally tied with: at least **2** strappings.
3. Longitudinally tied with: at least **2** strappings.
4. Protruding wrapping paper, running twists: **Max. 50mm per coil side.**
5. **For reasons of operational safety, only one coil (not several coils held in a unit) may be unloaded at a time.**

The products to be delivered must be accompanied by the *correct freight documents and information about quality, sizes, supplier, order number etc.*

### 2.2 Provisions for Unloading

We would like you to thoroughly read the unloading instructions stated below, in order to ensure a **safe** unloading of the cargo. The instructions were set up to enable a reasonable and safe unloading procedure.

Incoming ships must only be unloaded by using a coil grab. The following reloading instructions must now be observed in this context.

1. Coils must be stored and transported dry. The coil axis must be horizontal. The unloading is to be carried out under a cover sheet.
2. The distance to both front ends of the coils **must be at least 600mm** so that the coil grab can reach the coil. **The distance to the ship's side must be big enough to enable the coil grab to grab the coils without touching the ship's side.**
3. The unloading can only be carried out with a vertical movement. This is why no rolls may be stored below deck and the vertical unloading must not be obstructed by any bulkheads, structures, side decks etc.
4. Masts, structure, sleepers and hatch covers may not obstruct the unloading and must be removed by the carrier himself.
5. The use of special stowage material, e. g. steel constructions, must not result in exceptional delays or additional costs. Stowage material connected to the ship, e. g. nailed shell elements, will not be removed by SCG. The delivering party must conclude an agreement about this matter with the independent barge owner.
6. They will be invoiced the costs resulting from any damages to facilities or equipment that were caused by an incorrect loading of the ship.
7. **Delays during unloading resulting from a non-compliance with the instructions stated above can not be invoiced. Even in cases in which SCG is forced to refuse the unloading because of a non-compliance with the loading instructions, any costs arising thereof can not be invoiced.**
8. Docking at the harbour of SCG outside of operating hours is prohibited for reasons of operational safety.
9. **Operating Hours : Monday – Thursday 6:00 am – 10:00 pm**  
**Friday 6:00 am – 8:00pm**  
*The next public mooring place: Upper Water Lock /KM 24- northern side*
10. In case several ships must be unloaded, SCG will determine the order in which the ships will be unloaded.

## Loading Provisions

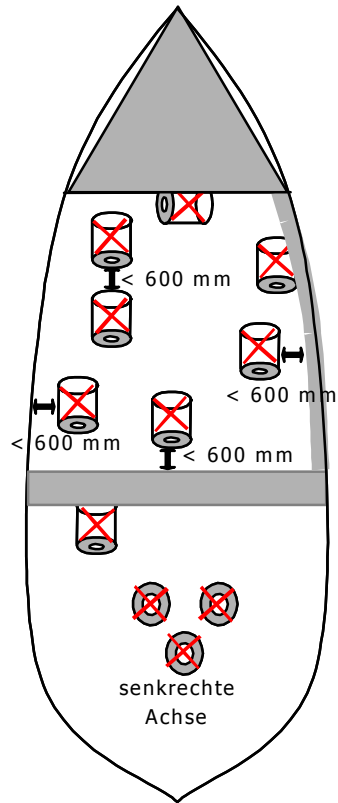

**✗ FALSCH**

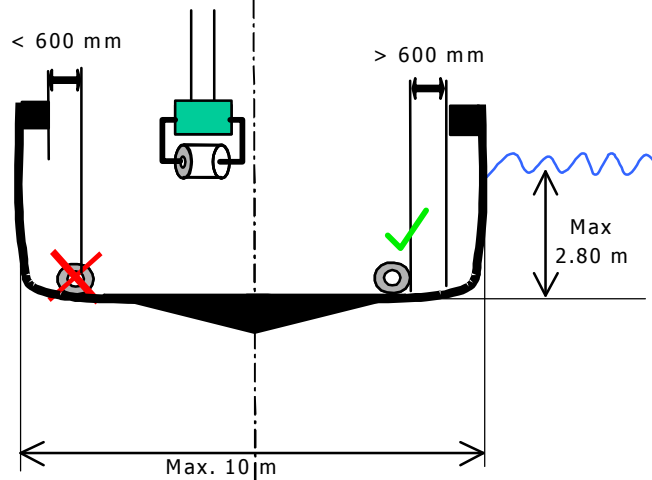

**✓ OK**

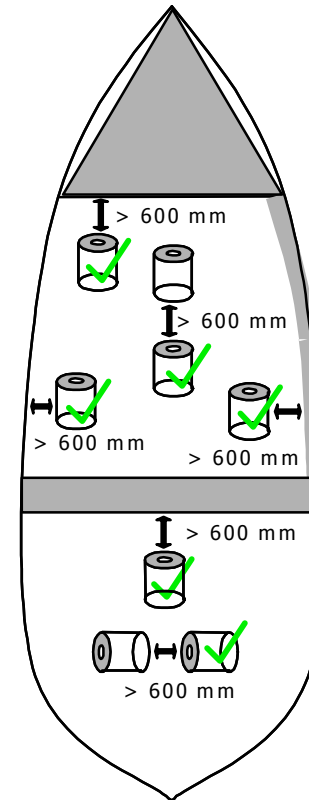

## 2.3 Registration

1. The supplier must contact the *purchasing department in order to agree on a delivery date* after the production of the material to be delivered has been completed.  
*Telephone number: +49 (0) 2 09/98 46-1 45*
2. The supplier must register *at least 24 hours before arrival providing the following information:*  
*sender/supplier*  
*weight*  
*number of rolls*  
*day of arrival in Gelsenkirchen*
3. *Packing lists must be clearly readable and are to be faxed to the purchasing department directly after loading, fax number: +49 (0) 2 09/98 46-2 30. All necessary customs documents and/or transport documents must be given to the SCG personnel responsible for incoming goods before unloading.*
4. Every ship is subject to the current *conditions of affreightment (GENCON TERMS)*.

**In case a ship does not have the right papers on its arrival, e. g. packing lists, customs documents, clearance document etc., it will not be unloaded.**

Not the physical arrival of the ship is considered to be the time of arrival but the handing over of the papers (at the earliest, the beginning of operations on the registration day) with regard to the calculation of the unloading days (unloading days, <550 t: 2 unloading days; 550<1000t: 3 unloading days; 1000<1500t: 3,5 unloading days; 1500<2000t: 4 unloading days).

*This is possible from Monday to Thursday from 06:00 am to 06:00 pm and on Friday until 02:00 pm.*

*Hafen Grimberg, Am Rhein-Herne Kanal at km 27.7 –28.06*

5. *Delays during unloading resulting from non-compliance with the loading regulations laid down in these instructions will NOT be considered unloading/lay days. This also applies if ships arrive too early or too late.*

### Note:

Ships may not be docked in the SCG harbour during the weekend (from Friday 08:00 pm to Monday 06:00 am).

*In these times, ships can dock at „Gelsenkirchen -Upper Water Lock - kilometre 24" - northern side for free.*

Company Management:                      Head of AS and UM                      Head of Purchase

*p.p. Markus Dötsch*

*p.p. Thomas Bischoff*

*p.p. Bernd Kündahl*